

K706 Series

Slim & Compact Relays

- Different colored test button for AC or DC
- Switch type On/Off structure for easy test
- LED indicator to show operation
- Socket with safety cover available



Ordering Information

K706 - 1PL D T - 12VDC

① ② ③ ④

① Contact Ratings	1PL	1NO / 1NC (1C)
	2PL	2NO / 2NC (2C)
② Option	no mark	None
	D	Diode (Only DC)
③ Function	no mark	None
	T	Test Button Type (AC : Red, DC : Blue)
④ Coil Voltage	12VDC	12VDC
	24VDC	24VDC
	24VAC	24VAC
	110VAC	110VAC
	230VAC	230VAC

Reference Data

Life cycle curve

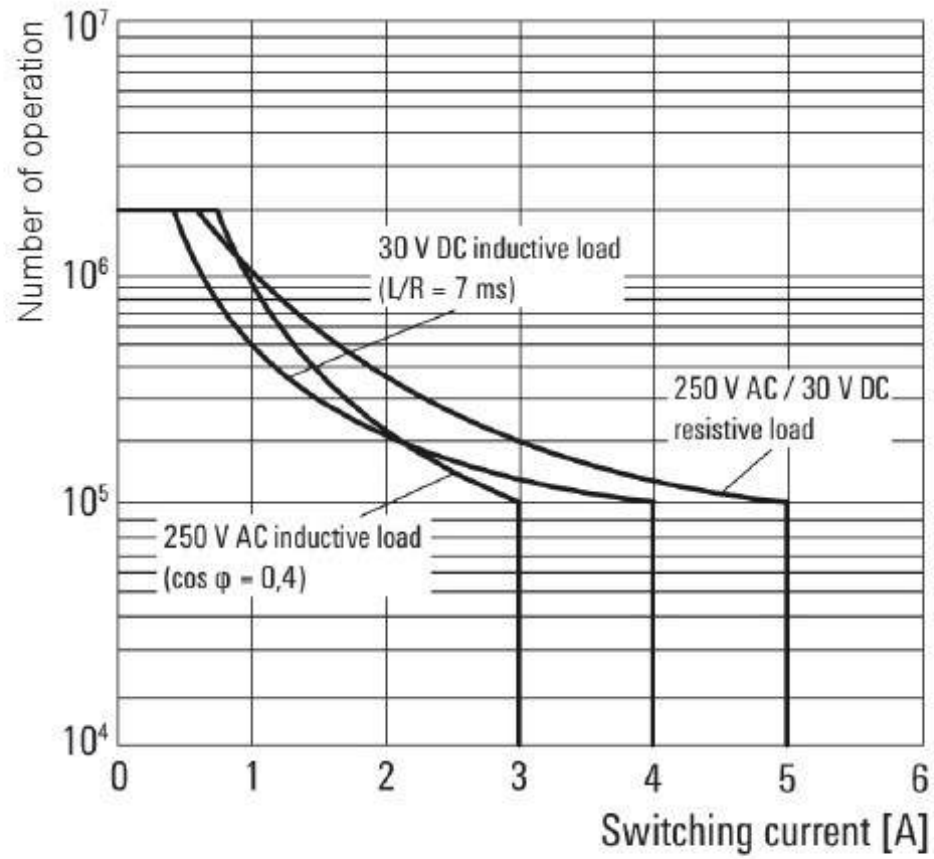

DC load breaking capacity

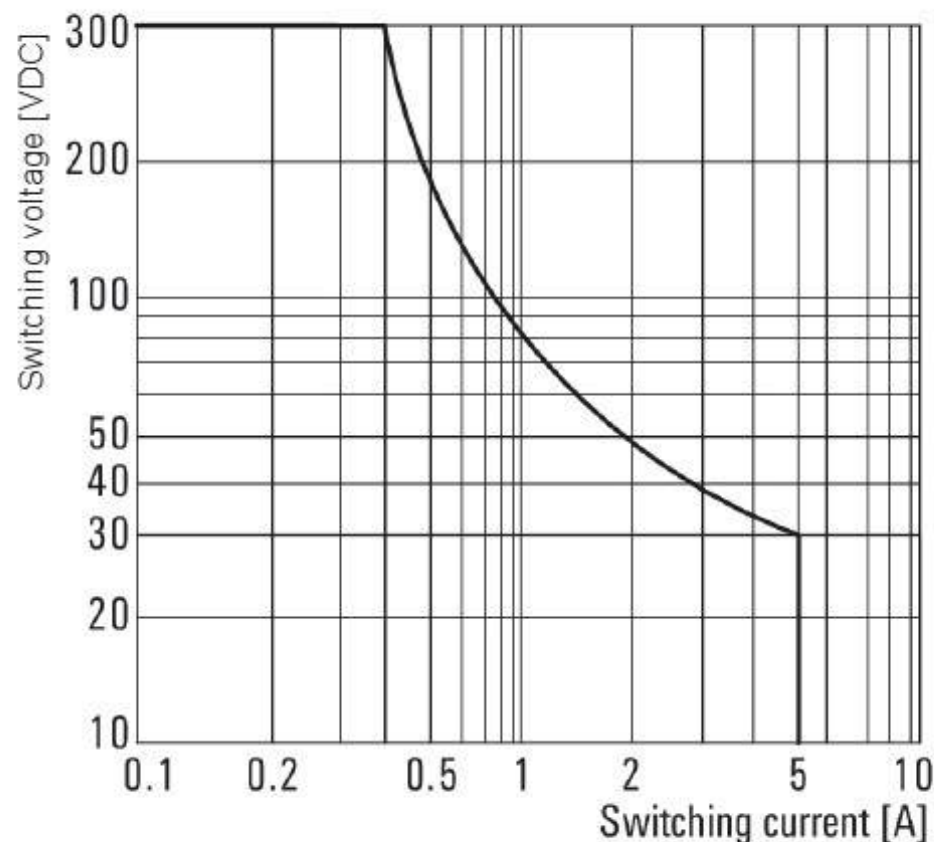

Specifications

Contact	Contact Arrangement	1NO / 1NC (1C)	2NO / 2NC (2C)	
	Contact Material	Ag alloy (24K Gold Plt.)		
	Max. Rated Current (Resistance Load)	10A / 250VAC	5A / 250VAC	
	Max. Switching Current	10A	5A	
	Max. Switching Capacity	3,000VA	2,000VA	
	Min. Switching Current*	100mA 5VDC		
	Initial Contact Resistance	100mΩ (1A 6VDC)		
Coil Spec.	Coil Voltage	12VDC, 24VDC, 24VAC, 100/110VAC, 220/240VAC		
	Coil Consumption	DC(W) : 0.53 / AC(VA) : 1.0		
	Min. Pick-up Voltage	DC : 75% of Nominal Voltage		
		AC : 80% of Nominal Voltage		
	Max. Dropout Voltage	DC : 10% of Nominal Voltage DC		
AC : 30% of Nominal Voltage AC				
General Info.	Operating Time	20ms		
	Release Time	10ms / Standard, 20ms / Diode		
	Insulation Resistance	1,000MΩ at 500VDC		
	Dielectric Strength	Between Contact Points	1,000Vrms 1min.	
		Between poles	3,000Vrms 1min.	
		Between Contact Points and Coil	5,000Vrms 1min	
	Life Cycle	Mechanical	Min. 10,000,000	
		Electrical	Min. 100,000	
	Vibration Resistant	Malfunction	10 ~ 55Hz (Durable Amplitude 1.5mm)	
		Destruction	10 ~ 55Hz (Durable Amplitude 1.5mm)	
Shock Resistant	Malfunction	98 m/s		
	Destruction	980 m/s		
Ambient Temperature	-40 ~ +55°C (with no Condensing)			
Ambient Humidity	35% ~ 85% RH			
Socket	Socket part number	KPX12/ KPX12-P	KPX22/KPX22-P	
	Terminal Tightened Torque	0.5N · m (5.10kgf · cm)		

*The minimum switching current is indicated as a standard value. The actual minimum switching rate is variable factor according to the make and break frequency, environmental condition and anticipated credibility level. Therefore, it is recommended that tests be done to test actual load value before the production process.

K706-1PL

Relays Dimensions (unit: mm)

Socket Dimensions (unit: mm)

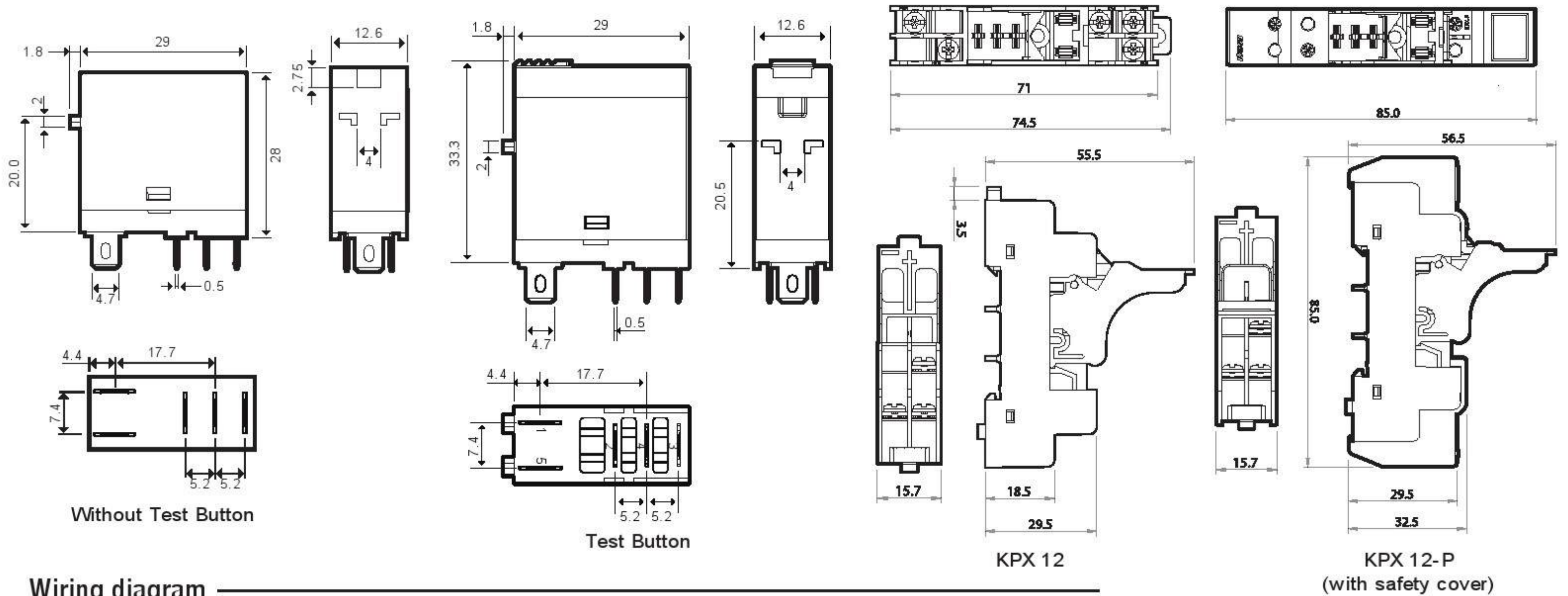

Wiring diagram

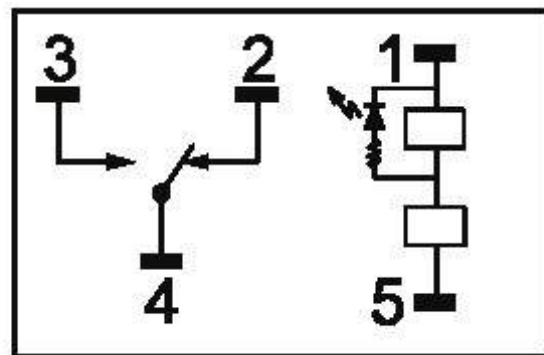

LED(AC)

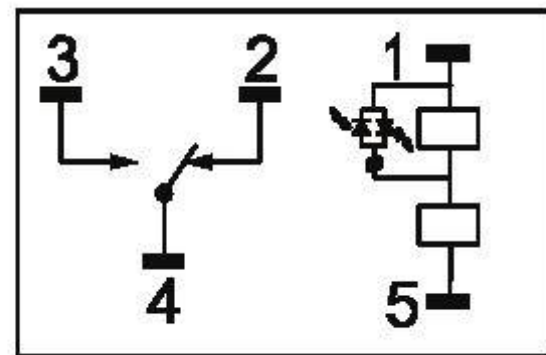

LED(DC)

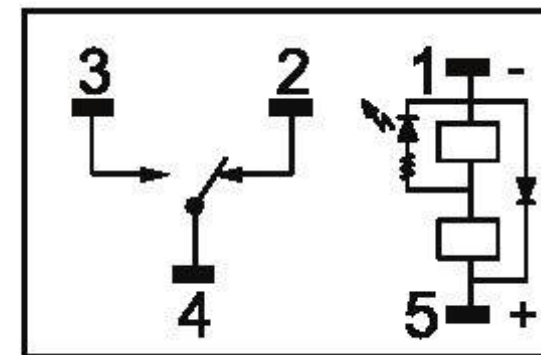

LED + Diode (DC)

K706-2PL

Relays Dimensions (unit: mm)

Socket Dimensions (unit: mm)

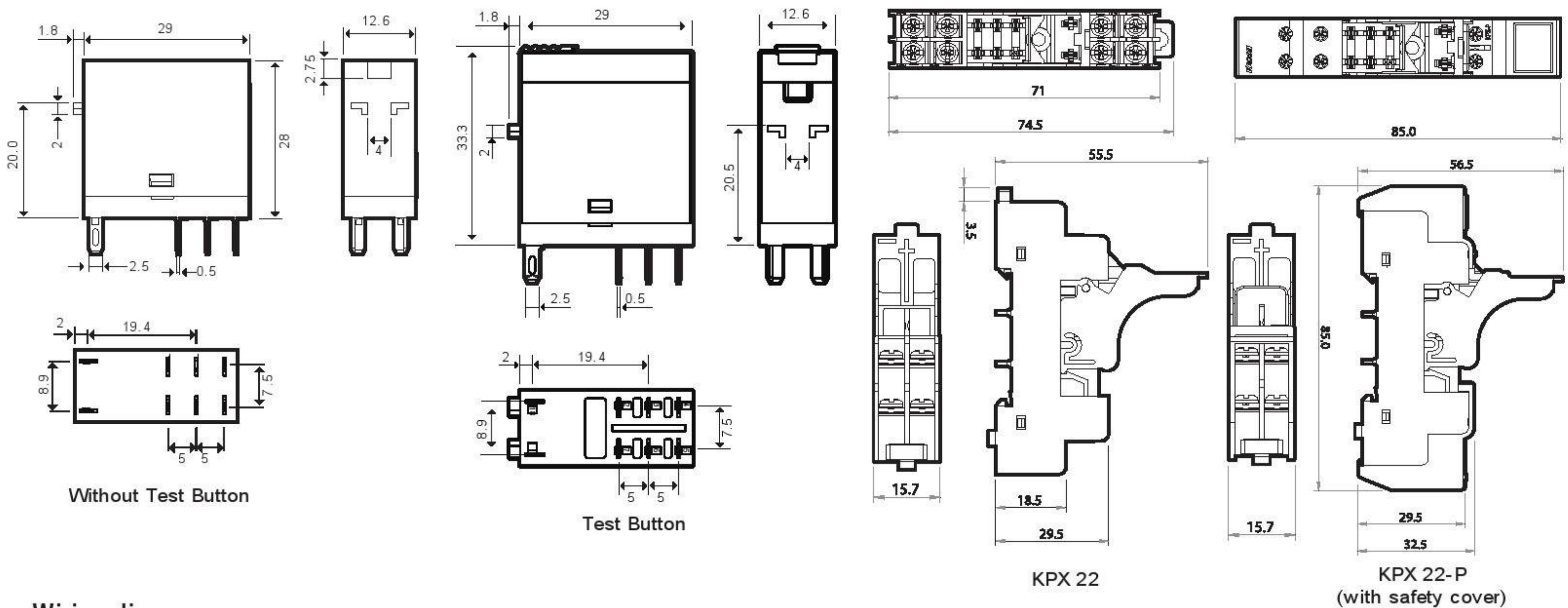

Wiring diagram

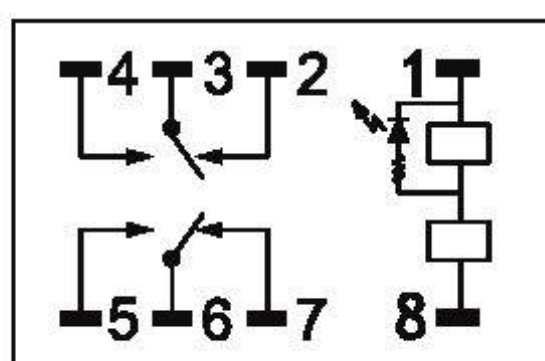

LED(AC)

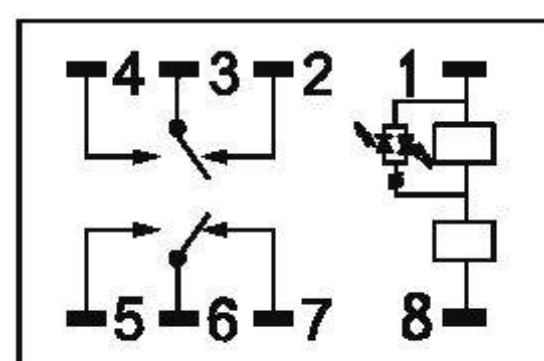

LED(DC)

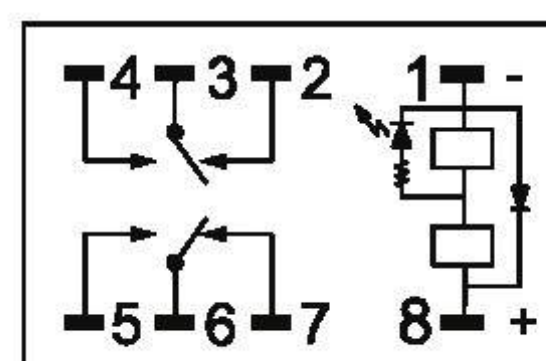

LED + Diode (DC)