

**Elimko**

Manufacturer / Technical Support  
Elimko Electronic Production and Control Co. Ltd.  
8. Avenue 68. Street No:16 06510 Emek- Ankara / TURKEY  
Phone: + 90 312 212 64 50 Fax: + 90 312 212 41 43  
[www.elimko.com.tr](http://www.elimko.com.tr) / e-mail:[elimko@elimko.com.tr](mailto:elimko@elimko.com.tr)

**Elimko**

E-PR-110  
Paperless Recorder  
User Manual



CE

Manufacturer / Technical Support  
Elimko Electronic Production and Control Co. Ltd.  
8. Avenue 68. Street No:16 06510 Emek- Ankara / TURKEY  
Phone: + 90 312 212 64 50 Fax: + 90 312 212 41 43  
[www.elimko.com.tr](http://www.elimko.com.tr) / e-mail:[elimko@elimko.com.tr](mailto:elimko@elimko.com.tr)



TS EN ISO 9001
Quality Management System Certificate

KY-PR110-0417-1

1 - INDEX

Table with 2 columns: Index Item and Page Number. Includes items like 1. INDEX (1-2), 2. FIGURES (3-6), 3. WARNINGS (7), 4. DESCRIPTION (8), 5. USAGE (14), 6. MENU PAGES (31), etc.

**1 - INDEX**

6.5.2. Ethernet Ayarları .....	42
6.5.3. Seri Port Ayarları .....	43
6.5.4. Ekran Ayarları .....	44
6.6. Kanallar .....	45
6.6.1.Röle Kartı Ayarları .....	46
6.6.2.Sayısal Çıkış Kartı Ayarları .....	47
6.6.3.Analog Giriş Kartı Giriş Ayarları .....	48 - 52
6.6.4.Analog Çıkış Kartı Ayarları .....	53 - 54
6.6.5.Alarm Ayarları .....	55 - 57
6.6.6.Toplayıcı Ayarları .....	58
6.6.7.Kayıt Ayarları .....	59 - 60
6.6.8.Sayısal Giriş Kartı Ayarları .....	61
6.6.9.Modbus Kanalları Sayfası .....	62 - 64
6.6.10.Matematik Kanal Ayarları .....	65
6.7. Gerçek Zaman Kanalları .....	66 - 67
6.8. Gruplar .....	68
6.9. Kullanıcı Tanımlı Tablolar .....	69
6.10. Arşiv .....	70 - 72
6.11. E-mail .....	73 - 76
6.12. PID .....	77 - 84
7. BAĞLANTI ŞEMALARI .....	85 - 91
8. VERİ TRANSFERİ VE İLETİŞİM PROTOKOLLERİ .....	92 - 93
9. EKLER .....	94
EK 1 Ethernet Bağlantısı .....	94 - 95
EK 2 Math Editor ile Eşitlik Girilmesi .....	96 - 98
EK 3 Modbus RTU İletişim Adresleri .....	99
EK 4 Barkod Okuyucu .....	100

**2 - FIGURES**

Şekil 4.1 E-PR-110 boyutları ve pano montaj aparatı .....	12
Şekil 4.2 E-PR-110 Panel Kesiti .....	13
Şekil 5.1 Trend Görünümü .....	14
Şekil 5.2 Operasyon tuşları .....	15 - 16
Şekil 5.3 Trend Görünüm Ekranı .....	17
Şekil 5.4 Trend görünüm ekranında aktif butonlar ve anlamları .....	18
Şekil 5.5 Trend görünüm ekranındaki aktif butonlar ve seçenekleri .....	19
Şekil 5.6 İşlem başlat ekranı .....	20
Şekil 5.7 Bar görünüm ekranı .....	21
Şekil 5.8 Sayısal görünüm ekranı .....	22
Şekil 5.9 Sayısal görünüm ekranında toplayıcı resetleme ve operatör mesajı ekleme .....	23
Şekil 5.10 Toplu görünüm ekranı .....	24
Şekil 5.11 Alarm Log ekranı alarm durumu .....	25
Şekil 5.12 Toplayıcı Log ekranı .....	26
Şekil 5.13 Cihaz Log ekranı .....	27
Şekil 5.14 Operatör Log ekranı .....	28
Şekil 5.15 Sayısal Log ekranı .....	29
Şekil 5.16 Sayısal 2 ekranı .....	30
Şekil 6.1 Ana Menüye giriş şifre penceresi .....	31
Şekil 6.2 Ana Menü .....	33
Şekil 6.3 Cihaz Bilgileri Sayfası .....	34
Şekil 6.4 Tarih – Saat Ayarlama Sayfası .....	34
Şekil 6.5 Güvenlik Ayarları Sayfası Admin Ayarı .....	35

**2 - FIGURES**

Şekil 6.6 Güvenlik Ayarları Sayfası Kullanıcı Ayarı .....	35
Şekil 6.7 Donanım Slot Ayarları Sayfası .....	36
Şekil 6.8 Donanım Röle Çıkış Test Sayfası .....	37
Şekil 6.9 Donanım Analog Giriş Kartı Kalibrasyon Sayfası .....	38
Şekil 6.10 Donanım Analog Çıkış Kartı Kalibrasyon Sayfası .....	40
Şekil 6.11 Donanım Ethernet Sayfası .....	42
Şekil 6.12 Donanım Ethernet Sayfası .....	42
Şekil 6.13 Donanım Seri Port penceresi .....	43
Şekil 6.14 Donanım Ekran Ayarları penceresi .....	44
Şekil 6.15 Çizim Opsiyonları penceresi .....	44
Şekil 6.16 Renk Seçim penceresi .....	44
Şekil 6.17 Slot Kanalları sayfası .....	45
Şekil 6.18 Röle Kartı Ayarları .....	46
Şekil 6.19 Sayısal Çıkış Kartı Ayarları .....	47
Şekil 6.20 Analog Giriş Kartı Giriş Ayarları .....	49
Şekil 6.21 Giriş Tipi Seçimi .....	50
Şekil 6.22 Termokupl seçimi .....	50
Şekil 6.23 Rezistans Termometre seçimi .....	50
Şekil 6.24 Giriş tipi Ohm, Milivolt, Miliamper ya da Volt seçilmiş ise Lineerleyici seçimi .....	50
Şekil 6.25 Giriş tipinin Termokupl seçili olmaması durumunda CJ Tipi, CJ Sıcaklık ve CJ Kaynak parametreleri .....	51
Şekil 6.26 CJ Tip seçim durumlarına göre CJ Sıcaklık ve CJ Kaynak parametrelerinin durumu .....	52

**2 - FIGURES**

Şekil 6.27 Analog Çıkış Kartı Kaynak Proses Değeri .....	53
ile Çıkış Değeri Değişimi .....	
Şekil 6.28 Analog Çıkış Kartı Ayarları .....	54
Şekil 6.29 Alarm 1 Seçimleri .....	56
Şekil 6.30 Alarm 2 Seçimleri .....	56
Şekil 6.31 Alarm Tip Seçimleri .....	56
Şekil 6.32 Low ve High Alarm Formları .....	57
Şekil 6.33 Slow Rate ve Fast Rate Alarm Formları .....	57
Şekil 6.34 Analog Giriş Toplayıcı ayarları .....	58
Şekil 6.35 Analog Giriş Kayıt ayarları .....	59
Şekil 6.36 Sayısal Giriş Kartı Giriş ayarları .....	61
Şekil 6.37 Sayısal Giriş Kartı Kayıt ayarları .....	61
Şekil 6.38 MODBUS Kanalları Sayfası .....	64
Şekil 6.39 Reg. Tipi seçenekleri .....	64
Şekil 6.40 Matematik Analog Sayfası .....	65
Şekil 6.41 Matematik Sayısal Sayfası .....	65
Şekil 6.42 Gerçek Zaman Kanalları (RTC) Sayfası .....	67
Şekil 6.43 Gerçek Zaman Kanalları (RTC) kaynak seçimi .....	67
Şekil 6.44 Gerçek Zaman Kanalları (RTC) periyod seçimi .....	67
Şekil 6.45 Gruplar Sayfası .....	68
Şekil 6.46 Gruplar Sayfası Grup seçimi .....	68
Şekil 6.47 Kullanıcı Tanımlı Tablolar Sayfası .....	69
Şekil 6.48 Analog Giriş sayfasında tablo seçimi .....	69
Şekil 6.49 Arşiv Senkronizasyon Sayfası .....	72

## 2 - FIGURES

Şekil 6.50 Arşiv Yedek Sayfası .....	72
Şekil 6.51 E-MAIL Sunucu Sayfası .....	73
Şekil 6.52 E-MAIL Alıcılar Sayfası .....	74
Şekil 6.53 E-MAIL Kaynaklar Sayfası .....	75
Şekil 6.54 E-MAIL Olaylar Sayfası .....	76
Şekil 6.55 PID Kontrol Kanalları Sayfası .....	77
Şekil 6.56 PID Kaynağın Analog Çıkışa Tanımlanması .....	80
Şekil 6.57 PID Kaynağın Röle Çıkışa Tanımlanması .....	81
Şekil 6.58 PID Kontrol Trend Görünüm .....	82
Şekil 6.59 PID Kontrol Set Noktasının Değiştirilmesi .....	83
Şekil 6.60 Toplu Görünüm Sayfası .....	84
Şekil 7.1 E-PR-110 Arka Panel .....	85
Şekil 7.2 Güç, Transmitter Besleme, RS-485 ve Ethernet Bağlantıları .....	86
Şekil 7.3 3 Kanallı Analog Giriş Kartı Bağlantı Şemaları .....	87
Şekil 7.4 6 Kanallı Analog Giriş Kartı Bağlantı Şemaları .....	88
Şekil 7.5 Sayısal Giriş ve Çıkış Kartı Bağlantı Şemaları .....	89
Şekil 7.6 Röle Çıkış Kartı Bağlantı Şeması .....	90
Şekil 7.7 Analog Çıkış Kartı Bağlantı Şeması .....	91
Şekil 9.1 Röle Çıkışı Kartı Bağlantı Şeması .....	94
Şekil 9.2 RJ 45 pin numaraları ve Crossover kablo bağlantısı .....	95
Şekil 9.3 MATH EDITOR Sayfası .....	97
Şekil 9.4 Script tuş seçimleri .....	97
Şekil 9.5 Operatör ve Fonksiyon Açıklamaları .....	98
Şekil 9.6 MODBUS Tablosu .....	99
Şekil 9.7 Sayısal Veri Bit Yerleşimi .....	99

## 3 - WARNINGS

E-PR-110 recorder is designed for panel mounting and should be used in industrial environment.

The package of E-PR-110 recorder contains;

Recorder  
2 pieces of mounting clamps  
1 piece M3 bolt nut  
User Manual  
Guarantee Certificate  
Elimko Data Explorer Pro Cd.

- After opening the package, please check the contents with the above list. If the delivered product is wrong type, any item is missing or there are visible defects, contact the vendor from which you purchased the product.
- Before installing and operating the controller, please read the user manual thoroughly.
- The installation and configuration of the recorder must only be performed by a person qualified in instrumentation.
- Keep the unit away from flammable gases that could cause explosion.
- Do not use alcohol or other solvents to clean the recorder. Use a clean cloth soaked in water tightly squeezed to gently wipe the outer surface of the recorder.
- Do not use any sharp objects or abrasives to avoid damaging the device.
- The product life of this instrument is 10 years.



- This recorder complies with the European Low Voltage Directive 2006/95/EC, by the application of safety standard TS EN 61010-1. (Pollution Degree 2)
- This recorder complies with the EMC Directive 2004/108/EC by the application of EMC standard TS EN 61326.

## 4 - DESCRIPTION

E-PR-110 series industrial recording and control devices complies with IEC/TR 60668 standard with its 144x144 mm front panel. These series has a high brightness and high resolution, 640x480 pixel TFT touch panel and features several analog and digital interfaces.

- 5.7 " , 640x480 , touch panel TFT screen
- Up to 24 universal Analog Input Channels
- Up to 18 Relay Outputs
- TCP/IP Modbus Master and Slave Protocol
- RS-485 Modbus Master and Slave Protocol
- Data connection with internal HTTP and FTP Server
- Up to 64 Digital Input Channels
- Up to 64 Digital Output Channel
- Analog çıkış?
- Standard RS-485 communication port
- 10/100 Mbit Ethernet Port
- Wi-Fi® (Optional)
- USB Host Port

## 4.1 - Type Coding

E-PR-110 - S1 - S2 - S3 - S4 - Y - Z



- 0 : Empty
- 1 : 03 Analog Input
- 2 : 06 Analog Input
- 3 : 06 Relay Output
- 4 : 16 Digital Input
- 5 : 16 Digital Output
- 6 : 04 Analog Output

### Operating Voltage

0 : 85 - 265 VAC,  
50-60 Hz / 85 - 375 V DC

### Wi-Fi

0 : Without Wi Fi  
1 : With Wi Fi

### Example

E-PR-110-1-1-1-1-0-0	12 (3+3+3+3) analog input
E-PR-110-1-1-3-3-0-0	6 (3+3) analog input, 12 (6+6) relay output
E-PR-110-1-4-4-3-0-0	3 analog input, 32 (16+16) digital input, 6 relay output
E-PR-110-1-1-1-5-1-0	9 (3+3+3) analog input, 16 digital output, with Wi-Fi
E-PR-110-4-4-4-5-1-0	48 (16+16+16) digital input, 16 digital output, with Wi-Fi

**NOTE:** The total number of relay and analog output should not exceed 18. Digital Output number is limited to 64.

## 4.2 - Technical Specification

Input Types	<b>TC</b> (B, E, J, K, L, N, R, S, T, U) <b>RT</b> (Pt-50, Pt-100, Pt-500, Pt-1000, Ni-100, Ni-200, Ni-500, Ni-1000) 0 ... 20 mA, 4 ... 20 mA, -2000 mV ... 2000 mV, 0 ... 10 V
Accuracy	<b>TC</b> : $\pm 0.5\%$ of the reading value or $\pm 1^\circ\text{C}$ <b>RT</b> : $\pm 0.5\%$ of the reading value or $\pm 1^\circ\text{C}$ Voltage / Current : $\pm 0.5\%$ FS
Operating Voltage	85 - 265 V AC; 50 - 60 Hz / 85-375 V DC
Power Consumption	30 W maximum
Data Storage Memory	8 GB Micro SD Flash
Communication	10 - 100 Mbit Ethernet, RS-485, USB Host, 802.11bgn 2.4GHz Wi-Fi®
Sampling Rate	100 ms (For all channels)
Configuration Ports	Touch Panel, USB Mouse and Keyboard connections
Screen Type	5.7" TFT LCD, 640x480 resolution, 18 bit color, Touch panel
Operating Temperature	0°C ... 50°C
Storage Temperature	-10°C ... 85°C
Analog Input	Max. 24 Analog Inputs 16 bit <sup>(1)</sup> (isolation of channels 1000 V AC )
Analog Output	0 – 20 mA / 0 – 10 V can be configured. Number of analog outputs is limited to 18 <sup>(1)</sup>

## 4.2 - Technical Specification

Digital Input	Max. 64 Digital Inputs <sup>(1)</sup>
Digital Output	Max. 64 Digital Outputs, 24 V DC, 40 mA <sup>(1)</sup>
Relay Output	Max. 18 Relay Outputs, SPST-NO; 250 V AC, 5 A Mechanical Life > 10.000.000 operation (The relay life depends on the usage configuration) Electrical Life > 1.000.000 operation (1/10 load)
Language	Turkish, English
Transmitter Supply <sup>(2)</sup>	
Password Protection	Adjustable different authority (Max. for 5 user)
Protection Class	Front Panel: IP65, Rear Panel: IP20
Weight	Approx. 1.6 kg

<sup>(1)</sup> Configuration dependent. Number of analog outputs, relay outputs and transmitter supply capacity are interdependently limited (See Section 4.1 Type Coding).

<sup>(2)</sup> The total number of 4-20 mA transmitters to be supplied, relay outputs and analog outputs should not exceed 16 ( $A+B+C \leq 18$ ) due to internal 24 V DC power limitation. This limitation is valid only with the assumption of all the output will be active at the same time.

For certain situations such as backup purposes, different output usage scenarios etc, the number of outputs could be increased. Please contact your sales provider for advise!!!

A= Number of 4-20 mA transmitters to be supplied

B= Number of Relay Outputs (number of individual outputs, not the number of cards, each relay output card has 6 relay outputs)

C= Number of Analog Outputs (number of individual outputs, not the number of cards, each analog output card has 4 analog outputs)

### 4.3 - Dimensions

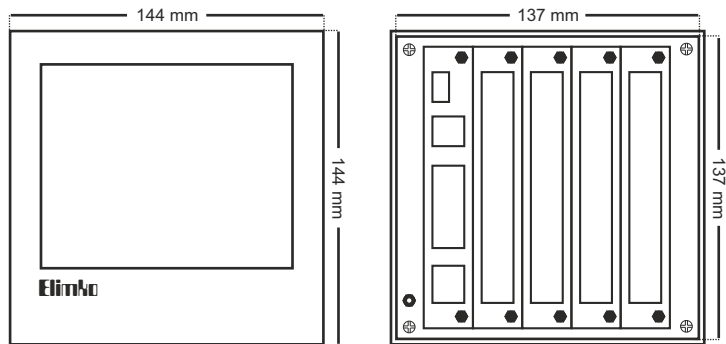
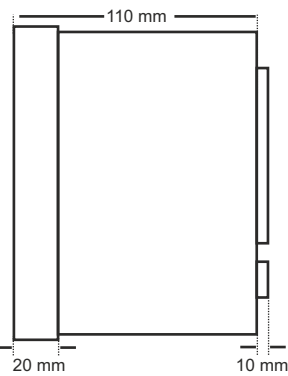

Figure 4.1  
E-PR-110 Dimensions  
and Panel Mounting



12

### 4.4 - Panel Mounting

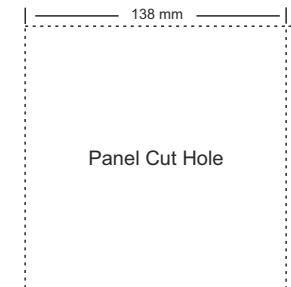

Figure 4.2 E-PR-110 Panel Cut Hole

- E-PR-110 device should be installed inside a suitable grounded metal enclosure (panel). This must prevent the live parts being accessible to human hands and metal tools. (See Section 7. CONNECTION DIAGRAMS).
- E-PR-110 does not include a power switch. Therefore, the power supply of the device and power outputs must be wired through the proper fuse or circuit breaker.
- To minimize the pick-up of electrical noise, the wiring of low voltage lines, particularly the sensor input should be routed away from the high-current power cables. Where it is not possible, use shielded cables which are grounded at both ends.
- The cables used for powering the controller and the power outputs must conform to the standards IEC 60245 and IEC 60227.



13



## 5 - USAGE

### 5.1 - Front Panel

In the event of a new alarm, the background color of the title area flashes between red and blue. After the alarms were acknowledged, the flashing ceases and the title area appears in blue (see Figure 5.1).

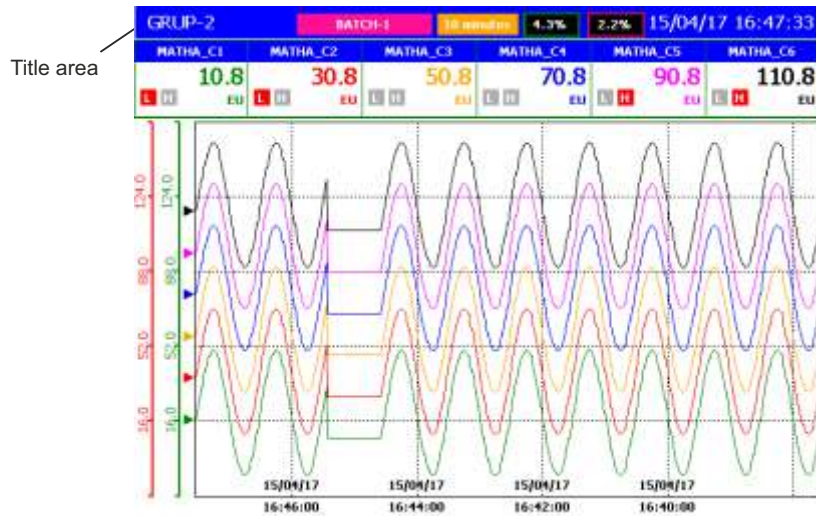

Figure 5.1 Trend View

### 5.1 - Front Panel

During normal operation, the operation buttons are hidden to increase the display area. Hidden operation buttons can be made visible by touching the bottom of the screen (see Figure 5.2). Explanations are given below regarding the operation buttons.

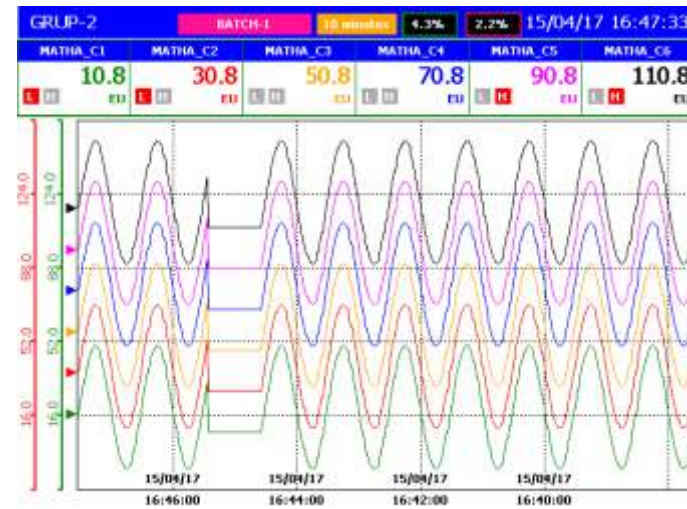

Figure 5.2 Operation Keys

The capacitive touch sensor device only works with the human hand and capacitive pens.



### 5.1 - Front Panel











OPERATION BUTTONS	
	This button is used to select one of the 6 groups and is active only TREND, BAR, DIGITAL and DIGITAL 2 views.
	This button is used to select any of the TREND, BAR, DIGITAL, OVERVIEW, ALARM LOG, TOTALIZER LOG, INSTRUMENT LOG, OPERATOR LOG, DIGITAL LOG, DIGITAL 2 and SCAN VIEWS options.
	This button allows the operator access to the menu of selected view. Each view has a different menu and detailed explanations of the menus are given in the related description of the views.
	This button is active only in the trend view. Used to increase or decrease the width of the screen.
	This button allows access to the configuration pages.
	Used to set up a Wi-Fi connection. If the Wi-Fi connection is not installed, the button  appears. This button is pressed to establish a Wi-Fi connection. In the window that opens, enter the network SSID and Password. The network connection is established by pressing the Connect button. If the network connection is established,  the symbol appears. Under the Wi-Fi icon, it writes the SSID of the connected network.

Figure 5.2 Operation Buttons

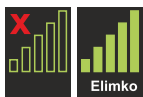
### 5.2 - Trend Page

Traces, process values, and alarm states of the channels in selected group are viewed. By pressing  button the menu given Figure 5.5 is opened. In Trend Page while not in History mode, newest recorded data is drawn on the screen continuously. To view historical data, History mode should be selected in Operator Menu. While in history mode, process values, date and time seen on the screen are the values at the time of cursor location. By touching the screen, the location of the cursor can be changed. While in history mode, date and time on the screen are written in red. By Go To Date, One Grid Forward, One Grid Back,   buttons, desired date and time can be chosen.

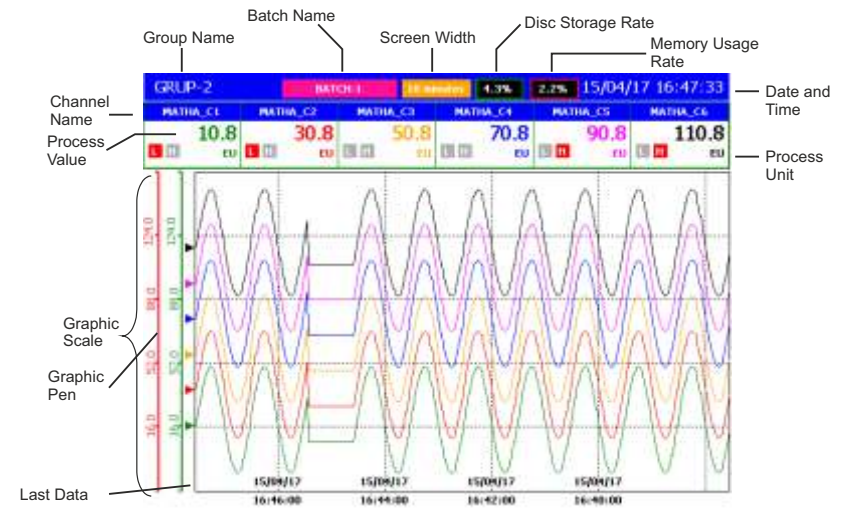

Figure 5.3 Trend View Screen

## 5.2 - Trend Page

<b>One Grid Forward</b>	Historical mode must be selected for this key to be active. This button scrolls the graph forward by a grid interval.
<b>One Grid Back</b>	Historically mode must be selected for this key to be active. This button scrolls the graph backwards by a grid interval.
<b>Start Batch</b>	Starts a new batch.
<b>Open/Stop Batch</b>	Opens batch management window in which user can stop running batches and open completed batches for review.
<b>History</b>	Selects Historical mode.
<b>Go To Date</b>	While History is selected, any past date can be chosen to review. The desired time can be entered by the keyboard.
<b>Screen Width</b>	Determines time interval that will be shown on the screen. According to selected sampling rate, some time intervals can appear disabled in a purpose to limit number of data points to be displayed.
<b>Traces</b>	The traces that desired to be seen can be chosen with this parameter. Desired traces can be opened or closed in Traces Menu.
<b>Axis</b>	The axis of the channel to be seen on the trend can be chosen with this parameter.
<b>Add Operator Message</b>	Adds operator messages. User must login in order to reach this menu. (see Section 6. MENU PAGES)
<b>Exit</b>	Used to exit the screen. The same operation can be performed by touching an empty area on the screen.

Figure 5.4 Active buttons and meaning in the Trend view screen

## 5.2 - Trend Page

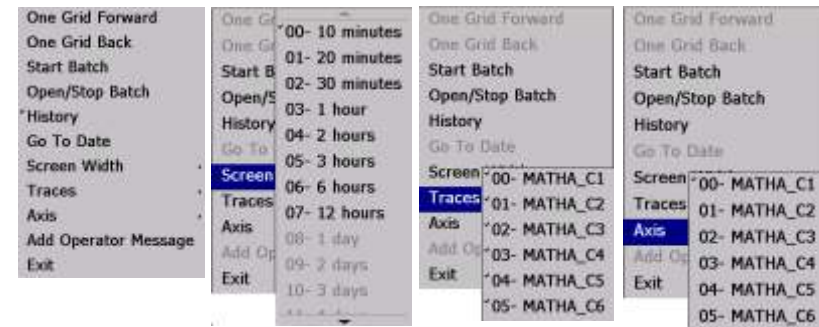

Figure 5.5 Active buttons and options on the Trend view screen

## 5.2 - Trend Page

Recording can be made continuously or batch base. To start a batch in any time, **Start Batch** is selected in **Operator Menu**. **Start Batch** screen will be opened as shown below. In this screen **Batch Name**, **Operator**, **Part No** and **Serial No** can be filled to any values depending on batch process and **Start** is selected. When the batch starts, Batch Name is written on the top of Trend Page. **Stop Batch** command in Operator Menu provide access to manage running and recorded batches. Start/Stop batch operations can also be performed with a barcode reader. (see Appendix 4)

Figure 5.6 Start Batch Screen

## 5.3 - Bar Graphic Page

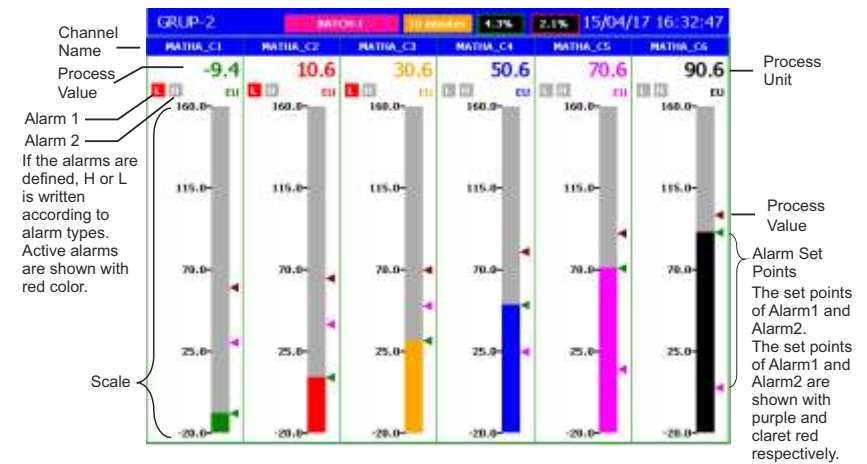

Figure 5.7 Bar View Screen

In Bar Graphic Page, bar graphics, process values, and alarm states of 6 channels in selected group are viewed.

5.4 - Digital View Page



Figure 5.8 Digital View Screen

In Digital View Page, totalizer values, process values, and alarm states of 6 channels in selected group are viewed.

5.4 - Digital View Page



Figure 5.9 Totalizer reset and add operator messages (Digital View Page)

<p><b>Reset Totalizer</b> ▶</p> <p><b>Add Operator Message</b></p> <p><b>Exit</b></p>	<p>Operator Menu for Digital View Page is opened by pressing [Menu] button. To reset the totalizer of an individual source, select the corresponding source name in sub menus of Reset Totalizer menu. To reset the totalizers of all sources in selected group, <b>All</b> can be selected.</p> <p><b>Add Operator Message:</b> Adds a operator message. It is only active when the user is logged in. (See Section 6. MENU PAGES).</p>
---	--



### 5.5 - Overview Page

All channels can be viewed in this page together. Process values of all available sources can be viewed in a single page. Each row in the page corresponds to a process group from one of the available slots, Modbus Channels or Math Analog Channels. Empty slots and undefined MATH and MODBUS channels are not shown. Analog process groups having more than 8 channels occupy two rows and due to overall row limitation, some of the process groups appears intermittently.



Figure 5.10 Batch Screen View

### 5.6 - Alarm Log



Figure 5.11 Alarm Log screen

The last occurred and released 10000 alarms with date and definitions are listed in Alarm Page. The latest alarm is on the top of the list. The list can be scrolled by pressing ▲ and ▼ buttons. Active alarms are shown in red color and released alarms are shown in green color. Active alarms which appear in red turn green after the alarms were acknowledged by selecting **Acknowledge Alarms** parameter.

<b>Acknowledge</b>	Operator Menu for Alarm Page can be opened with  button. Alarms are acknowledged with selecting <b>Acknowledge Alarms</b> parameter.
<b>Exit</b>	

## 5.7 - Totalizer Log

TOTALIZER LOG			
BATCH-1		10 records	4.3% 2.1% 15/04/17 16:38:17
NO(1/477)	SOURCE	DATE	VALUE/UNIT
10385	MODBUSTOT_C1	30/03/16 15:58:26	0
10384	MODBUSTOT_C1	30/03/16 15:58:14	0
10383	MODBUSTOT_C1	30/03/16 15:58:02	0
10382	MODBUSTOT_C1	30/03/16 15:57:50	0
10381	MODBUSTOT_C1	30/03/16 15:57:38	0
10380	MODBUSTOT_C1	30/03/16 15:57:26	0
10299	MODBUSTOT_C1	30/03/16 15:57:14	0
10298	MODBUSTOT_C1	30/03/16 15:57:02	0
10297	MODBUSTOT_C1	30/03/16 15:56:50	0
10296	MODBUSTOT_C1	30/03/16 15:56:38	0
10295	MODBUSTOT_C1	30/03/16 15:56:26	0
10294	MODBUSTOT_C1	30/03/16 15:56:14	0
10293	MODBUSTOT_C1	30/03/16 15:56:02	0
10292	MODBUSTOT_C1	30/03/16 15:55:50	0
10291	MODBUSTOT_C1	30/03/16 15:55:38	0
10290	MODBUSTOT_C1	30/03/16 15:55:26	0
10289	MODBUSTOT_C1	30/03/16 15:55:14	0
10288	MODBUSTOT_C1	30/03/16 15:55:02	0
10287	MODBUSTOT_C1	30/03/16 15:54:50	0
10286	MODBUSTOT_C1	30/03/16 15:54:38	0
10285	MODBUSTOT_C1	30/03/16 15:54:26	0

Figure 5.12 Totalizer Log screen

Source Name, record date, totalizer value and unit of the last recorded 10000 totalizer values are listed in Totalizer Page. The last recorded totalizer is displayed at the top of the list. Totalizer values can be scrolled by ▲ and ▼ buttons. The time intervals of totalizers are defined with the **Logging Source** parameter of related Totalizer.

## 5.8 - Instrument Log

INSTRUMENT LOG		
10 records		4.3% 2.0% 19/04/17 09:11:23
NO(1/49)	DATE	DEFINITION
16604	19/04/17 09:08:36	KILLANCI-5 is logged
16603	19/04/17 09:08:21	KILLANCI-2 is logout
16602	19/04/17 09:07:26	KILLANCI-2 is logged
16601	19/04/17 09:07:11	ADMIN is login
16600	19/04/17 09:06:11	ADMIN is logged
16599	19/04/17 09:03:02	RTC base sync. OK
16598	19/04/17 09:02:40	E-PR-110 starts
16597	18/04/17 17:44:28	RTC base sync. OK
16596	18/04/17 17:44:06	E-PR-110 starts
16595	18/04/17 17:30:49	ADMIN is logged
16594	18/04/17 17:37:59	RTC base sync. OK
16593	18/04/17 17:37:39	E-PR-110 starts
16592	15/04/17 16:45:26	RTC base set was completed successfully
16591	15/04/17 16:43:59	ADMIN is logged
16590	15/04/17 16:43:24	ADMIN is logout
16589	15/04/17 13:04:09	ADMIN is logged
16588	15/04/17 13:03:57	RTC base sync. OK
16587	15/04/17 12:53:07	E-PR-110 starts
16586	15/04/17 13:03:12	ADMIN giris yapti
16585	15/04/17 13:02:38	RTC zaman aytilmesi basariyla tamamlanab
16584	15/04/17 12:51:48	E-PR-110 açılış

Figure 5.13 Instrument Log screen

The date and definition of last recorded 1000 events of the device are listed in Instrument Log Page. The last recorded event appears on the top. ▲ and ▼ buttons are used to scroll the list up or down.

## 5.9 - Operator Log

OPERATOR LOG			
NO(1/1)	DATE	OPERATOR	DEFINITION
5	19/04/17 09:09:02	KULLANICI-5	SMALL FIRIN ARIZA
4	19/04/17 09:09:12	KULLANICI-2	SMALL FIRIN COK YUKSEK SICAKLIK
3	19/04/17 09:06:50	ADMIN	SICAKLIK SUREKLI DEGISIYOR
2	01/09/15 14:13:09	ADMIN	asöwe
1	01/09/15 13:55:33	ADMIN	1233wg

Figure 5.14 Operator Log screen

Operators can add messages anytime while operating the device in order to assert certain events and information. In order to add messages, the operator must login first and should press Add Operator Message menu in the Operator Menu. Operator message with descending date order are listed in Operator Log Page. ▲ and ▼ keys scrolls the page up and down direction (see Section 5.2 TREND PAGE and 5.4 DIGITAL VIEW PAGE).

## 5.10 - Digital Log

DIGITAL LOG			
NO(1/39)	SOURCE	DATE	DEFINITION
816	DIN_C11	19/04/17 09:18:32	DIN_C11 OFF
815	DIN_C11	19/04/17 09:18:30	DIN_C11 ON
814	DIN_C7	19/04/17 09:18:25	DIN_C7 OFF
813	DIN_C7	19/04/17 09:18:25	DIN_C7 ON
812	DIN_C5	19/04/17 09:18:23	DIN_C5 OFF
811	DIN_C5	19/04/17 09:18:22	DIN_C5 ON
810	DIN_C6	19/04/17 09:18:16	DIN_C6 OFF
809	DIN_C6	19/04/17 09:18:13	DIN_C6 ON
808	DIN_C16	19/04/17 09:18:10	DIN_C16 OFF
807	DIN_C15	19/04/17 09:18:10	DIN_C15 OFF
806	DIN_C14	19/04/17 09:18:10	DIN_C14 OFF
805	DIN_C13	19/04/17 09:18:10	DIN_C13 OFF
804	DIN_C18	19/04/17 09:18:10	DIN_C18 OFF
803	DIN_C3	19/04/17 09:18:10	DIN_C3 OFF
802	DIN_C16	19/04/17 09:18:05	DIN_C16 ON
801	DIN_C15	19/04/17 09:18:05	DIN_C15 ON
800	DIN_C14	19/04/17 09:18:05	DIN_C14 ON
799	DIN_C13	19/04/17 09:18:05	DIN_C13 ON
798	DIN_C18	19/04/17 09:18:05	DIN_C18 ON
797	DIN_C3	19/04/17 09:18:05	DIN_C3 ON
796	DIN_C16	19/04/17 09:18:04	DIN_C16 OFF

Figure 5.15 Digital Log screen

Source Name, record date and definition of the last recorded 65536 digital log values are listed in Digital Log Page. The last recorded digital log value is displayed at the top of the list. Digital log values can be scrolled by ▲ and ▼ buttons.

**Acknowledge  
Exit**

Operator Menu for Digital Log Page can be opened by pressing  button. Alarms are acknowledged by selecting **Acknowledge** digital logs menu.

**Note:**

In "NO(X/Y)" column, X is page number and Y is number of pages.





## 5.11 - Digital 2

GRUP-2		
MATHA_C1	MATHA_C2	MATHA_C3
44.3 <sub>EU</sub> <sup>L</sup>	64.3 <sub>EU</sub> <sup>L</sup>	84.3 <sub>EU</sub> <sup>H</sup>
MATHA_C4	MATHA_C5	MATHA_C6
104.3 <sub>EU</sub> <sup>H</sup>	124.3 <sub>EU</sub> <sup>H</sup>	144.3 <sub>EU</sub> <sup>H</sup>
MATHA_C1	MATHA_C2	MATHA_C3
44.3 <sub>EU</sub> <sup>L</sup>	64.3 <sub>EU</sub> <sup>L</sup>	84.3 <sub>EU</sub> <sup>H</sup>
MATHA_C4	MATHA_C5	MATHA_C6
104.3 <sub>EU</sub> <sup>H</sup>	124.3 <sub>EU</sub> <sup>H</sup>	144.3 <sub>EU</sub> <sup>H</sup>

Figure 5.16 Digital 2 screen

Two consecutive groups (selected group and the following group which may wrap to first or last group depending on selected group) can be viewed digitally on the same page.

## 6 - MENU PAGES

Pressing  key accesses to Menu page. Upon pressing  key authentication window opens and user name/ password are asked. After selecting UserName and Password, main menu is reached by either pressing MENU or LOGIN button. LOGIN access does not require authentication on subsequent entries until LOGOUT is pressed from Main Menu. Depending on previously defined authorization rights, some of the sub menus may appear disabled (see Section 6.4. Security). Default values for the user password are given:

USERS	PASSWORD
ADMIN	10
USER 2	02
USER 3	03
USER 4	04
USER 5	05
USER 6	06

PASSWORD	
User	KULLANICI-2
Password	
<input type="button" value="LOGIN"/> <input type="button" value="MENU"/> <input type="button" value="CANCEL"/>	

PASSWORD	
User	ADMIN
Password	##
<input type="button" value="LOGIN"/> <input type="button" value="MENU"/> <input type="button" value="CANCEL"/>	

Figure 6.1 Password input window to the main menu

## 6.1 - Adjusting Parameters

All of the parameters can be adjusted by touch panel. An example of a parameter editing screen is given below.



The parameter window of the parameter to be adjusted should be touched in order to access adjustment page.

## 6.2 - Main Menu

Detailed descriptions of the pages that can be accessed from the main menu are described in the sections indicated in **Figure 6.2**. **OS** button allows access to the operating system. All operating systems menus are hidden as factory settings. To access to the start menu of the OS, pointer of the mouse connected to the USB port must be dragged down to the bottom edge of the screen.

Please check the **6. MENU PAGES** section for **LOGOUT** button. **EXIT** button allows operator to exit from the main menu. **MODBUS TABLE** button provides access to Modbus RTU Communication Addresses (**see Appendix 3**).



Figure 6.2 Main Menu

### 6.3 - Device Page

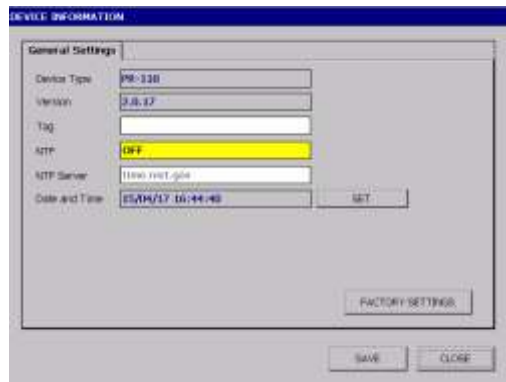

Figure 6.3 Device Page



Figure 6.4 Date and Time adjustments page

In Device Page, Device Type and Version are shown. Date and Time adjustments and factory settings reset are made in this page.

**Tag:** Tag value determines synchronization directory name and alias of the device therefore should be unique for each recorder in order to prevent data corruption when same data storage media is used for data synchronization.

**NTP:** Enables or disables network time protocol. When enabled, date/time is synchronized every 6 hours by connecting NTP server defined in **NTP Server** parameter.

In case of a connection problem, the synchronization is retried every 1 hour until the connection is established.

**NTP Server:** The NTP Server name is entered.

### 6.4 - Security Page

User names, passwords and access rights of users are determined in Security Page. There is no restriction for **ADMIN** user rights and access rights of other users are determined by **ADMIN** user.

<b>User</b>	Determines the user that will be adjusted.
<b>Name</b>	Determines the user name. The name can consist of 15 characters at most.
<b>Password</b>	Determines the password of selected user. The password can consist of 10 characters at most.
<b>Access Rights</b>	The rights of the users below <b>Access Rights</b> headline can be chosen <b>ON</b> or <b>OFF</b> .

After adjusting security settings, the adjustments should be saved by pressing **SAVE** button.



Figure 6.5 Security Adjustments Page (Admin Adjustment)



Figure 6.6 Security Adjustments Page (User Adjustment)

## 6.5 - Hardware Page

The hardware adjustments are made in this page. **HARDWARE Page** consists of 4 tabs as **Slot**, **Ethernet**, **Serial Port** and **Screen**.

### 6.5.1 - Slot Adjustments

The calibration parameter adjustment resides in this tab. Any erroneous operation in Analog Input Card Calibration Page will corrupt the calibration parameter and measurements become faulty. The parameters of this page are adjusted by precision measurement and source devices. If accurate calibration devices are not available, any recalibration attempt is not advised. 

In case of any modification on slot hardware, **SCAN** button in Slot Tab should be selected to activate slot configuration. After scanning of the cards, card types on the slots are viewed in SLOT1, SLOT2, SLOT3, SLOT4, SLOT5, SLOT6, SLOT7, SLOT8 and SLOT9 windows. To calibrate or test a card, corresponding slot window should be selected. All of the cards are calibrated in the factory and do not need recalibration.



Figure 6.7 Hardware Slot Settings Page

### 6.5.1 - Slot Adjustments

#### Relay Output Test Page

Output states of the Digital Output cards for test purposes can be changed by pressing corresponding ON and OFF buttons. There is no testing and calibration page of digital input cards. Like the digital output cards, relays states can be changed by pressing ON or OFF in Relay Card Test page for test purposes.

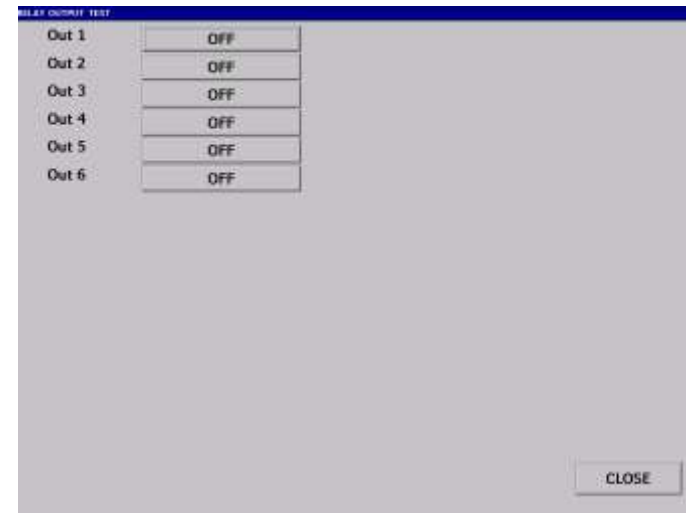

Figure 6.7 Hardware Relay Output Test Page

### 6.5.1 - Slot Adjustments

#### Analog Input Card Calibration Adjustments

For the calibration of Analog Input cards, firstly, the channel to be calibrated should be selected from **Channel** window. The calibration parameters are explained below. From a general point of calibration operations, required signals specified below are applied to the corresponding channels and **Press to Calibrate** button is pressed. After stable value was seen, the value is recorded by selecting the same button. **Cancel** button is used to cancel active calibration.

The **Manual Set** button allows manual entry of the calibration value via the keyboard. The **Load Factory Settings** button resets the calibration values to factory settings.

Channel	Channel 1		
50 mV	20462	Press to calibrate	Press to set
TC (SHORT)	-10	Press to calibrate	Press to set
CJ-NTC (3 k)	4168	Press to calibrate	Press to set
20 mA	26047	Press to calibrate	Press to set
10 V	23279	Press to calibrate	Press to set
390 Ohm	19577	Press to calibrate	Press to set
390 Ohm Line	-15	Press to calibrate	Press to set

LOAD FACTORY SETTINGS      CLOSE

Şekil 6.9 Analog Input Card Calibration Page

### 6.5.1 - Slot Adjustments

#### Analog Input Card Calibration Adjustments

**50 mV:** Set the calibrator as a millivolt source and adjust the calibrator output 50.000 mV. Apply the calibrator output to the millivolt input of the related channel.

**TC (SHORT), CJ-NTC (3 k):** Set the calibrator as a resistance source and adjust the calibrator output 3000.00 Ohm. Short circuit the TC input terminals of the related channels. Apply the calibrator output to the input terminals of the related channel.

**20 mA:** Set the calibrator as a milliampere source and adjust the calibrator output 20.00 mA. Apply the calibrator output to the milliampere input of the related channel.

**10 V:** Set the calibrator as a voltage source and adjust the calibrator output 10.00 V. Apply the calibrator output to the volt input of the related channel.

**390 Ohm:** Set the calibrator as a resistance source and adjust the calibrator output 390.00 Ohm. Apply the calibrator output to the RT input of the related channel. 3. RT line should be short-circuited by the wiring diagram.

**390 Ohm Line:** Same as 390 Ohm. Just save after making 390 ohm calibration without changing anything

### 6.5.1 - Slot Adjustments

#### Analog Output Card Calibration Adjustments

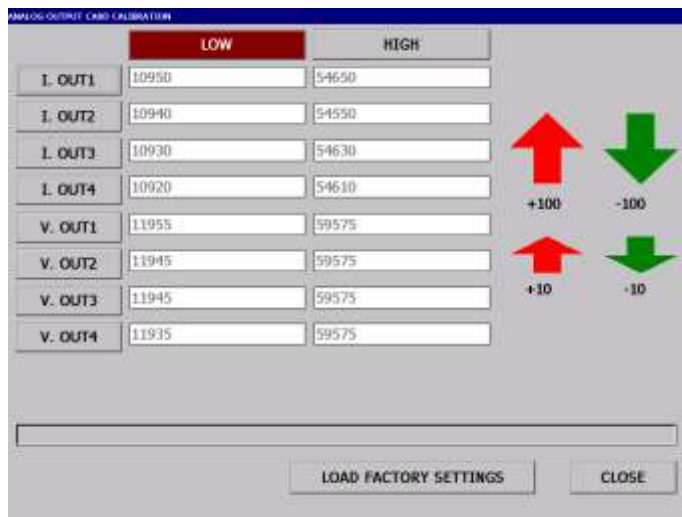

Figure 6.10 Analog Output Card Calibration Page

### 6.5.1 - Slot Adjustments

#### Analog Output Card Calibration Adjustments

The current and voltage outputs of analog output channels provided with Analog Output cards can be calibrated on the screen given in Figure 6.10. For each current and voltage outputs, 2 LOW and 2 HIGH calibration values must be saved. By selecting the channels to be calibrated from left of the screen (I.OUT 1-4, V.OUT1-4), and calibration type HIGH or LOW from top of the screen, calibration process is initiated for selected output type and calibration value.

After this process, the font color of selected channel and calibration type turn burgundy, the calibration value ??screen turns yellow. A Voltmeter (3(-), 4(+)) or ampermeter (1(+), 2(-)) is connected to the outlet of the channel depending on the type of calibration of the selected channel.

The value of the calibration is set using the up and down keys. For ease of calibration, up and down keys are given as two pieces of 100 levels and 10 levels. 100 steps for coarse changes, 10 steps are used for fine adjustments. LOW and HIGH calibration values of current outputs are 4 mA and 20 mA respectively. LOW and HIGH calibration values of voltage output is 2 V and 10 V respectively. Calibration values are saved by pressing corresponding channel button which has been turned to burgundy to initiate calibration. To cancel the calibration process, press the CANCEL button under the screen.

The **Load Factory Settings** button resets the calibration values to factory settings.

### 6.5.2 - Ethernet Adjustments

TCP/IP settings are done by defining the **IP Address**, **Subnet Mask** and **Default Gateway**. Definitions of these parameters are made either manually or automatically by DHCP depending on selected IP type. If TCP/IP application needs fixed IP address, user is recommended to use Manual Settings. **Save** button saves the settings restarts the device.

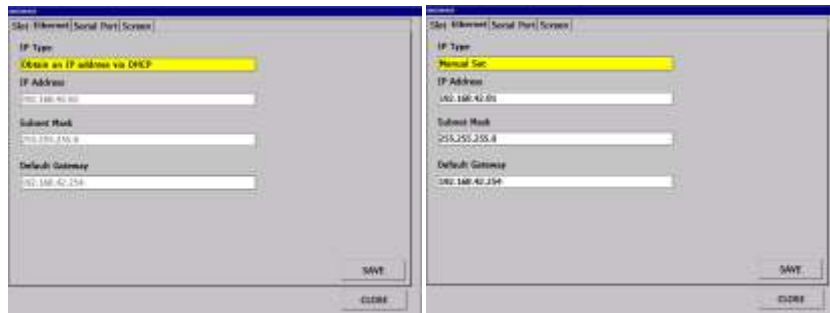

Figure 6.11 Hardware Ethernet Page (Obtain an IP address via DHCP)

Figure 6.12 Hardware Ethernet Page (Manual Set)

### 6.5.3 - Serial Port Adjustment

The communication parameters of RS-485 port (Boud Rate, Parity and Stop Bit) are adjusted in this tab.

<b>Modbus Type:</b>	Set as either master or slave.
<b>Address:</b>	Determines modbus slave communication address. Only functional when slave mode is selected.
<b>Baud Rate, Parity and Stop Bit</b> determine serial communication parameters.	

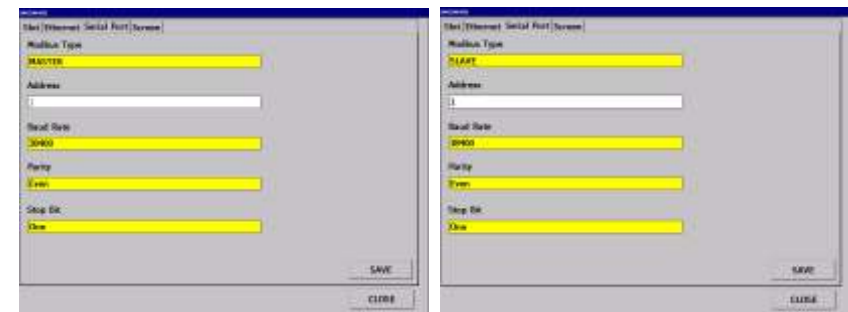

Figure 6.13 Hardware Serial Port screen

### 6.5.4 - Screen Adjustment

<b>Language:</b>	The language of the device can be chosen either Turkish or English.
<b>Brightness:</b>	This parameter determines the brightness of the screen. Brightness can be adjusted between %20 and %100.
<b>Screen Saver:</b>	ON or OFF selectable.
<b>Screen Saver Time:</b>	Determines the time period after that the device starts screen saver if no operation takes place.

DRAWING OPTIONS button opens color selection window in which trace colors of the group channels can be configured as desired. In addition to trace colors, the background and foreground (standart text color and line color) can be chosen. Please take precaution while assigning the colors in order to prevent conflicting color selection. Assigning same colors to the channels may cause confusion and setting same color to background and any of the channels causes the channel traces disappear.



Figure 6.14 Hardware Screen Adjustments



Figure 6.15 Drawing Options Adjustments

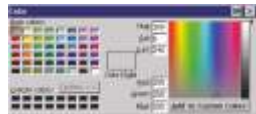

Figure 6.16 Color Selection Screen

### 6.6 - Channels Page

After selecting the slot from top window and the channel from the left buttons, related content is loaded to the screen. After required adjustment, **SAVE** button saves the values.

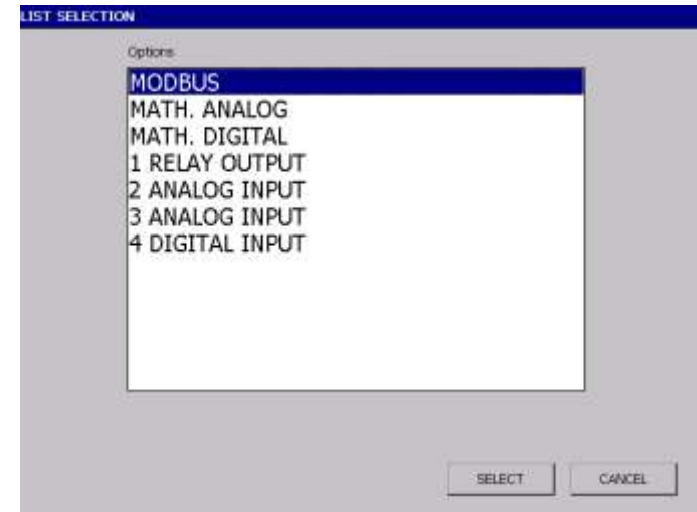

Figure 6.17 Slot Channels Page



6.6.1 - Relay Output Card Adjustments

<b>Name:</b>	The name of the related Relay Output can be written by this parameter. (maximum length of 12 characters)
<b>Description:</b>	Maximum 50 characters long description.
<b>Off Message:</b>	Maximum 100 characters long alarm off message.
<b>On Message:</b>	Maximum 100 characters long alarm on message.
<b>Source 1-5:</b>	When any of digital <b>Source 1 to 5</b> becomes ON, the relay output activates (energised)
<b>PWM Source:</b>	PWM source can be assigned to one of the 12 PID, relay or digital output sources.
<b>PWM Period:</b>	Determines the PWM period when a PWM Source other than the PID Sources is assigned.

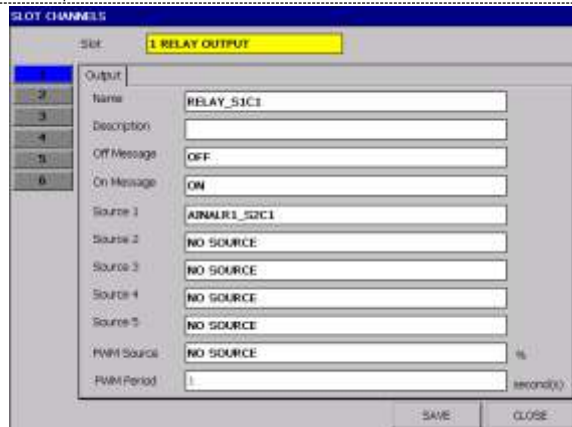

Figure 6.18 Relay Output Card Adjustments

6.6.2 - Digital Output Card Adjustments

Please see section 6.6.1 for a description of parameters.

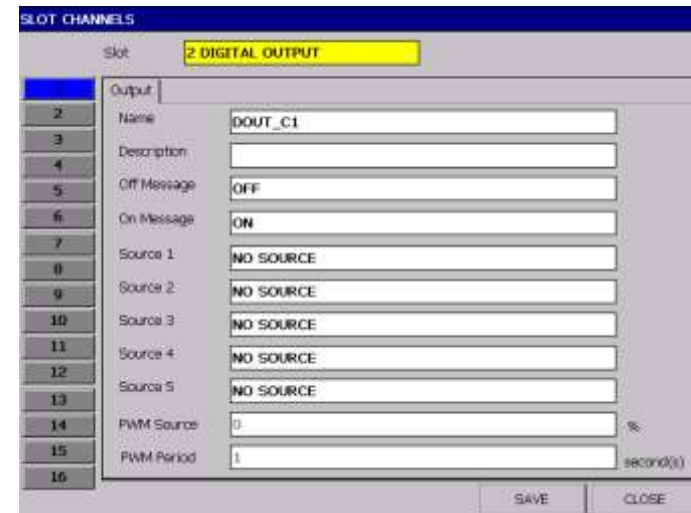

Figure 6.19 Relay Output Card Adjustments

### 6.6.3 - Analog Input Card Adjustments

<b>Name:</b>	The channel can be named with using maximum 12 characters.
<b>Description:</b>	Maximum 50 characters long description.
<b>Input Type:</b>	Determines input type. The parameter can be selected as, <b>Thermocouple, Resistance Thermometer, Ohm, Milivolt, Miliampere or Volt.</b>
<b>Range Low:</b>	Determines minimum input value that will be applied to the channel. This parameter is active only for linear inputs.
<b>Range High:</b>	Determines maximum input value that will be applied to channel. This parameter is active only for linear inputs.

Range Low - Range High Values for Linear Inputs are given below.

INPUT	Min. Input	Max. Input
Miliampere	-20 mA	20 mA
Milivolt	-2000 mV	2000 mV
Ohm	0 ohm	5000 ohm
Volt	-10 V	10 V

<b>Linearization:</b>	Determines sensor type for Thermocouple and Resistance Thermometer and how to linearize the Linear Inputs while the process value is calculated.
<b>Decimal Point:</b>	Determines the position of decimal point. The parameter can be adjusted as <b>0, 0.0, 0.00 or 0.000.</b>
<b>Zero - Span:</b>	Determines process value for TC and RT sensors in the case of sensor break depending on <b>Sensor Break</b> parameter. The parameter determines the scale for linear inputs.
<b>Sensor Break:</b>	Determines process value in the case of sensor break. Process value will be equal to Zero when <b>SET LOW</b> is selected and will be equal to Span when SET HIGH is selected.

### 6.6.3 - Analog Input Card Adjustments

<b>Shift Value:</b>	Determines shift value of process value.
<b>Unit:</b>	Determines the unit of the input.
<b>CJ Type:</b> <b>CJ Temperature:</b> <b>CJ Source:</b>	Determines the cold junction compensation type for TC inputs. <b>DISABLED</b> selection disables the compensation. <b>CONSTANT</b> selection fixes the cold junction temperature to CJ Temperature parameter. <b>RESERVED and EXTERNAL</b> selections use external E-CJ-NTC-01 terminal NTC sensor. <b>CHANNEL CJ</b> selection assigns cold junction temperature to the cold junction temperature of another channel defined by <b>CJ Source</b> and likewise <b>CHANNEL</b> selection assigns cold junction temperature to the process value of the channel defined by <b>CJ Source</b> .

Figure 6.20 Analog Input Card Input Adjustments

6.6.3 - Analog Input Card Adjustments



Figure 6.21 Input Type Selection

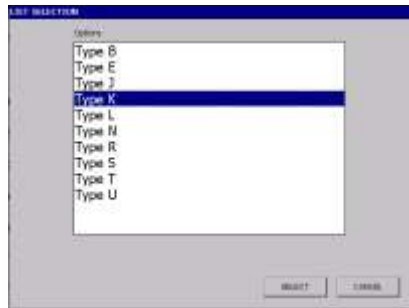

Figure 6.22 Linearization Select (Input Type Selection)



Figure 6.23 Linearization Select (Input Type Resistance Thermometer)



Figure 6.24 Linearization Select (Input Type Ohm, Millivolt, Milliampere or Volt)

6.6.3 - Analog Input Card Adjustments

CJ Type, CJ Source and CJ temperature parameters are active only TC inputs (see Figure 6.25). For TC sensor connection, **E-CJ-NTC-01 compensation sensor** should be used when the CJ Type is selected as EXTERNAL. 

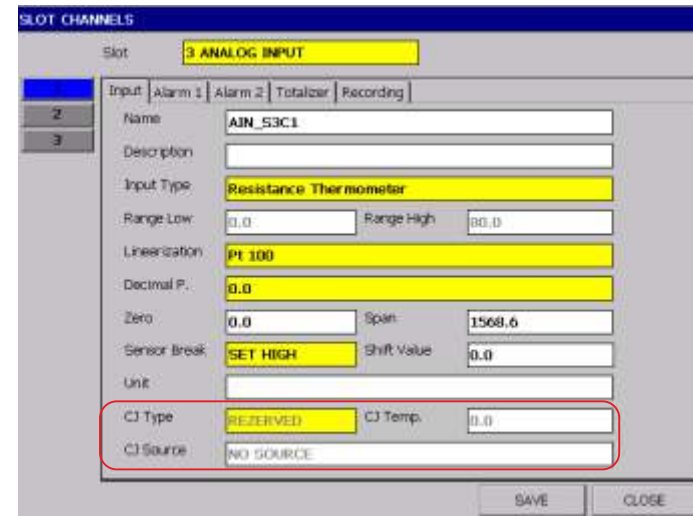

Figure 6.25 Disabled CJ Type, CJ Temperature and CJ Source parameters

6.6.3 - Analog Input Card Adjustments

**CJ Type**

<input type="checkbox"/> Type	DISABLED	CJ Temp.	0.0
<input type="checkbox"/> Source	AIN_54C1		
<input type="checkbox"/> Type	CONSTANT	CJ Temp.	0.0
<input type="checkbox"/> Source	AIN_54C1		
<input type="checkbox"/> Type	REZERVED	CJ Temp.	0.0
<input type="checkbox"/> Source	AIN_54C1		
<input type="checkbox"/> Type	EXTERNAL	CJ Temp.	0.0
<input type="checkbox"/> Source	AIN_54C1		
<input type="checkbox"/> Type	CHANNEL CJ	CJ Temp.	0.0
<input type="checkbox"/> Source	AIN_54C1		
<input type="checkbox"/> Type	CHANNEL	CJ Temp.	0.0
<input type="checkbox"/> Source	AIN_54C1		

**DISABLED** selection disables the compensation. **CONSTANT** selection fixes the cold junction temperature to **CJ Temp** parameter. **RESERVED** and **EXTERNAL** selections use external E-CJ-NTC-01 terminal NTC sensor. **CHANNEL CJ** selection assigns cold junction temperature to the cold junction temperature of another channel defined by **CJ Source** and likewise **CHANNEL** selection assigns cold junction temperature to the process value of the channel defined by **CJ Source**.

Figure 6.26 CJ Type selections

6.6.4 - Analog Output Card Adjustments

<b>Name:</b>	The related channel input can be named with using maximum 12 character.
<b>Description:</b>	Maximum 50 characters long description.
<b>Source:</b>	Determines the analog source by which the analog output is controlled .
<b>Type:</b>	Output type mA or Volt can be selected. Only one of them can be activated at a time.
<b>Min:</b>	Minimum value of the output. For <b>mA</b> outputs, the value should be in the range of 0 to 20 mA, for <b>Volt</b> outputs should be in the range of 0 to 10 V.
<b>Max:</b>	Maximum value of the output. For <b>mA</b> outputs, the value should be in the range of 0 to 20 mA, for <b>Volt</b> outputs should be in the range of 0 to 10 V.
<b>Zero:</b>	Together with the <b>Span</b> parameter, determines the analog output scale. When the process value of the source channel equals to <b>Zero</b> value, the output is set to <b>Min</b> output value.
<b>Span:</b>	Together with the <b>Zero</b> parameter, determines the analog output scale. When the process value of the source channel equals to <b>Span</b> value, the output set to <b>Max</b> output value.

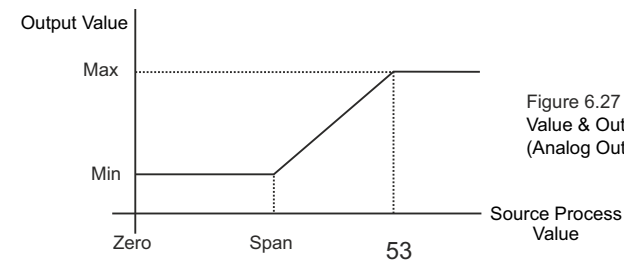

Figure 6.27 Source Process Value & Output Value (Analog Output Card)

### 6.6.4 - Analog Output Card Adjustments

209 CHANNELS

Slot: 3 ANALOG OUTPUT

Output | Recording

2

3 Name: ADOUT\_C1

4 Description:

Source: NO SOURCE

Type: mA

Min: 0.0

Max: 20.0

Zero: 0.000

Span: 200.000

SAVE CLOSE

Figure 6.28 Analog Output Card Adjustments

### 6.6.5 - Alarm adjustments

For each **Math Analog, Analog Input** and **Modbus channels**, two alarms are defined and can be configured to several output forms (see **Figure 6.30** and **Figure 6.31**).

<b>Name:</b>	Maximum 12 characters long alarm name. Any character string can be entered in order to name the alarm.
<b>Type:</b>	Any of <b>OFF, LOW, HIGH, SLOW RATE, FAST RATE</b> alarm types can be assigned to alarms. Please check <b>Figure 6.30</b> and <b>Figure 6.31</b> for output forms.
<b>Set/Deviation:</b>	Defines set point for LOW and HIGH alarm types; deviation for SLOW RATE and FAST RATE types.
<b>Hysteresis:</b>	Defines alarm hysteresis for LOW and HIGH alarms.
<b>Latch Enable:</b>	Enabling latch causes alarm on state to persist until being acknowledged even if the alarm condition is over.
<b>Delay:</b>	Alarms can be delayed for a certain amount of time in order to make sure the alarm condition persists long enough. Any value between 0 and 9999 can be set in seconds.
<b>Derivation Time:</b>	Define derivation time for SLOW and FAST RATE alarms. Please check <b>Figure 6.33</b>
<b>Filter:</b>	Process values can be averaged in order to smooth unavoidable abrupt changes which may cause false alarms. The filter value which can be set to any value from 1 to 10 determines number of process values to be averaged for alarm calculations.
<b>Off Mesajı:</b>	Maximum 100 characters long alarm off message.
<b>On mesajı:</b>	Maximum 100 characters long alarm on message.

6.6.5 - Alarm adjustments

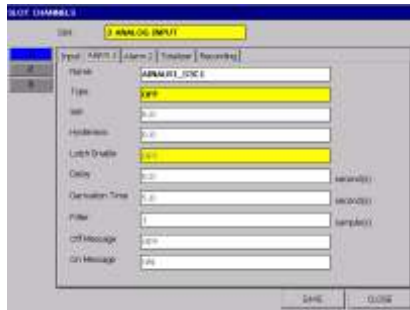

Figure 6.29 Alarm 1 Type selection



Figure 6.30 Alarm 2 Type selection



Figure 6.31 Alarm Type selection

6.6.5 - Alarm adjustments

Working forms of alarm types are described below.

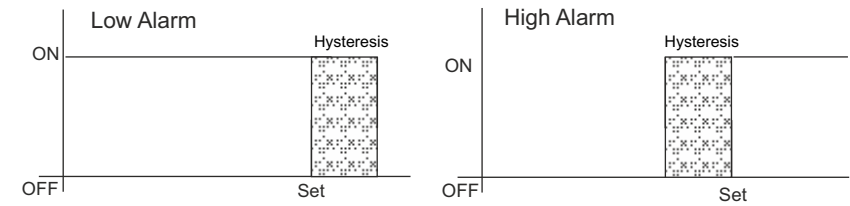

Figure 6.32 Low and High Alarm Forms

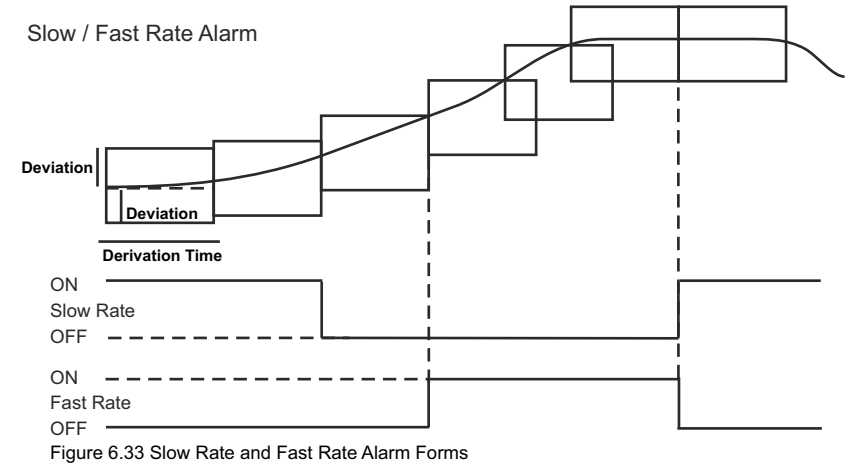

Figure 6.33 Slow Rate and Fast Rate Alarm Forms

### 6.6.6 - Totalizer Adjustments

One totalizer is defined for each slot analog input, math analog and Modbus analog channels.

<b>Name:</b>	Totalizer of related channel can be named with using 12 characters.
<b>Enable:</b>	Determines if totalizer is active or not.
<b>Period:</b>	Determines time unit of channel to be totalled. The parameter can be selected as <b>/Second</b> , <b>/Minute</b> or <b>/Hour</b> .
<b>Cutoff:</b>	Determines the lowest process value that the totalizer will be active.
<b>Unit:</b>	Determines the unit of totalizer.
<b>Reset Source:</b>	Determines digital source for reset.
<b>Logging Source:</b>	Determines digital source for logging.

Figure 6.34 Analog Input  
Totalizer Adjustments

58

### 6.6.7 - Record Adjustments

<b>Enable:</b>	Determines whether the channel recording is activated or not. The parameter can be selected as <b>ON</b> or <b>OFF</b> .
<b>Sampling:</b>	Determines the recording period.
<b>Filter:</b>	Sampling period of the internal ADCs are fixed at 100 ms regardless of recording period. For each recording period option, certain number of sampled values are collected depending on selected recording period (Total Number Of Samples = Recording Period (ms) / 100). Filter parameter determines the way how these sampled values will be processed prior to the recording. If <b>Instantaneous</b> is set for filtering, the value at the time of recording is recorded. Maximum and Minimum selects the maximum and minimum of the sampled values respectively for recording. Average value of the sampled values can be recorded using <b>Average Filter</b> .

Figure 6.35  
Analog Input  
Record Adjustments

59

### 6.6.7 - Record Adjustments

Changing the recording period parameter causes losing of the relevant channel's archived data recorded in that day at which the modification takes place. Daily memory usage for each recording channel can be calculated using below equation in bytes.

**Memory Usage (Bytes) = (86400/Recording Period (sec))\*4**

As an example, when all slots are plugged with Analog Input Cards and the recording of all analog channels are activated with a 1 sec recording period, 350 Kbytes of memory is used for each channel in a day and that corresponds to 4.2 MByte memory usage for all channel. With 8000 MByte Micro SD Flash, recording belonging to the last 5 years can be hold internally without any corruption. When the internal memory is full, old records are either deleted or backup depending on Backup Type. Please see **Archive Page** for backup configuration (see **Section 6.10**).

### 6.6.8 - Digital Input Card adjustments

State changes in all digital input channels are recorded to **DIGITAL LOG**. In addition, the channels can also be recorded periodically. Please check section **6.6.7 Record Adjustments** for digital input card for periodic recording.

<b>Name:</b>	The name of the related digital input can be written by this parameter (maximum length of 12 characters).
<b>Description:</b>	Maximum 50 characters long description.
<b>Off Mesajı:</b>	Maximum 100 characters long alarm off message.
<b>On mesajı:</b>	Maximum 100 characters long alarm on message.



Figure 6.36 Digital Input Card, Input adjustments



Figure 6.37 Digital Input Card, Recording adjustments



### 6.6.9 - MODBUS Channels Page

Up to 16 MODBUS RTU channels can be configured by this page. Firstly, channel number is clicked from the left of the screen before starting the configuration. MODBUS channel process values are transferred from slave MODBUS RTU devices over the RS-485 port or TCP. RS-485 serial communication settings can be done from Serial Port Tab in the **HARDWARE** menu. Slot Analog Channel and MODBUS channel have almost same features except the way channel process values are assigned. While the former extracts the channel values from certain sensors, the latter uses RS-485 bus or TCP by querying the slave device with **Device Address** and **Reg. Address** parameters to get the channel process values. If an error occurs while querying the slave device, the process value of the relevant channel is set to the configured **Fault Value**.

<b>Name:</b>	Determines the name of the selected channel with using maximum 12 characters.
<b>Description:</b>	Maximum 50 characters long description.
<b>Connection:</b>	This parameter determines connection type. When selected as OFF, the channel is disabled and is closed for message transaction. Available connections are RS-485 and TCP.
<b>Time Out:</b>	Only functional for RS-485 connections and determines time out value in milliseconds. This parameter can be adjusted between 100 and 500 milliseconds.
<b>Address:</b>	This parameter defines modbus slave address of RS-485 modbus connection and can be set between 1 and 127.
<b>IP Address:</b>	This parameter determines IP address of TCP/IP connection and is only required for TCP type connections.
<b>Function:</b>	Determines the function code which will be used when querying. 03 or 04 can be selected.
<b>Reg. Start Adr.:</b>	Starting address of modbus reading query.
<b>Reg. Count:</b>	Number of register to be read in query.

### 6.6.9 - MODBUS Channels Page

<b>Index:</b>	When the <b>Address</b> , <b>Reg. Start Adr.</b> and <b>Reg. Count</b> parameters are set to the same values for more than one channel, the <b>Index</b> parameter determines the register which will be assigned to channel process value. By this way, number of transaction can be decreased in order to increase query frequency by using same transaction for more than one channel.
<b>Reg. Type:</b>	<ul style="list-style-type: none"> <li>- Short (Signed 2 Byte), Short (Unsigned 2 Byte),</li> <li>- Integer (Signed 4 Byte), Integer (Unsigned 4 Byte),</li> <li>- Long (Signed 8 Byte), Long (Unsigned 8 Byte),</li> <li>- Float ( 4 byte)</li> </ul>
<b>Decimal Point:</b>	Determines the position of decimal point. The parameter can be set as <b>0</b> , <b>0.0</b> , <b>0.00</b> or <b>0.000</b>
<b>Fault Value:</b>	Determines the value of the channel in fault status.
<b>Bitim:</b>	Determines the unit.

6.6.9 - MODBUS Channels Page

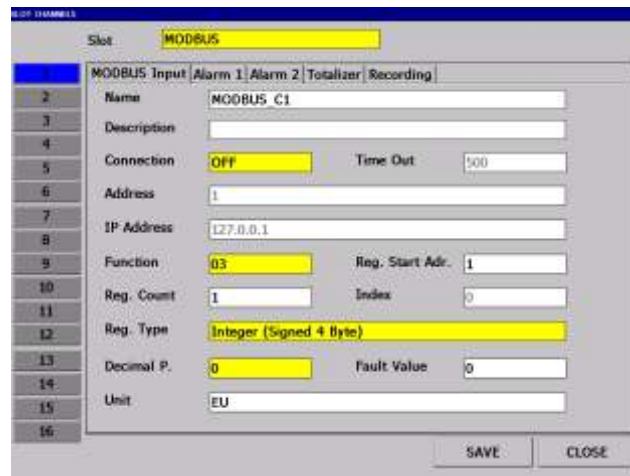

Figure 6.38 MODBUS Channels



Figure 6.39 Register Types

6.6.10 - Math Channel Adjustments

Equation assignable 16 Analog Mathematics and 16 Digital Mathematics channel are available on device. Analog math channel parameters are same as the slot analog channel parameters except the input parameters. Instead of input selection, equations are assigned for math. channels. Digital math channel parameters are same as the slot digital channel parameters except the recording parameters. Periodic recording is not available for digital math channels but state changes are logged to the Digital Log page.

<b>Equation:</b>	The equation can be defined using <b>MATH EDITOR</b> screen (See Appendix 2).
<b>Fault Value:</b>	Determines the value of the Math Channel when there is a problem in the calculation of math equation like divide by Zero etc.

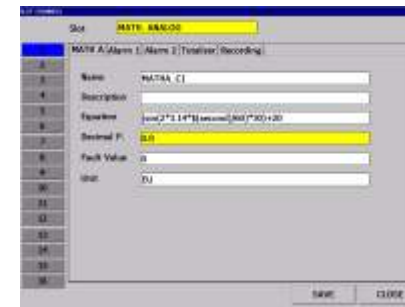

Figure 6.40 Math Analog Page

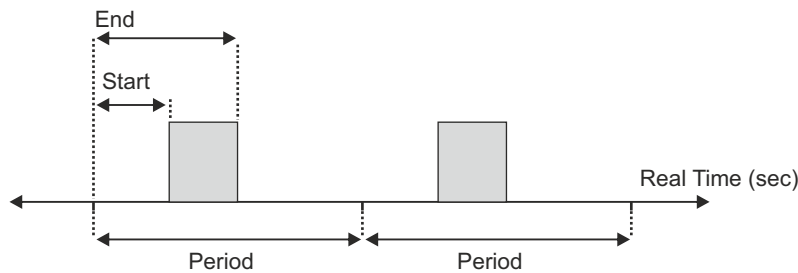

Figure 6.41 Math Digital Page

### 6.7 - Real Time Channels Page

**Period, Start, and End** parameters determine the real time interval in which the related real time source will be active as shown below. For example if **Period, Start, and End** are adjusted as **Every Minute, 0, 5** respectively, the related channel will be active in first 5 seconds of every minute. Unit of **Start** and **End** parameters are in seconds. Real Time channels can be used for Totalizer Log Source, Totalizer Reset Source, Periodic Alarm etc.

<b>Source:</b>	Real Time channel to be adjusted.
<b>Name:</b>	Desired channel can be named with maximum 12 characters.
<b>Description:</b>	Maximum 50 characters long description.



### 6.7 - Real Time Channels Page

Figure 6.42 Real Time Channels (RTC) Page

Figure 6.43 Real Time Channels (RTC) source selection

Figure 6.44 Real Time Channels (RTC) period selection

## 6.8 - Groups Page

6 process group with 6 channels can be defined in the device. The channels of the process groups can be chosen from slot analog channels, modbus channels or math analog channels. After selecting the channels and their scales, these channels can be viewed in **Bar Graphic, Digital and Trend Pages**. The Digital 2 page shows two consecutive groups at the same group. As shown in **Figure 6.46** selected group (\*) appear in the display indicates that the group was configured.

<b>Group:</b>	Selects the group to be adjusted.
<b>Adı:</b>	The group name can be determined with maximum 12 characters.
<b>Tanim:</b>	Maximum 50 characters long description.
<b>Minimum:</b>	Determines minimum value of the scale.
<b>Maximum:</b>	Determines maximum value of the scale.



Şekil 6.45 Goups Page



Şekil 6.46 Goups Page - Group Selection

## 6.8.1 - Changing Alarm Set Values in Trend View

While the user is in Trend view, the alarm set value can be changed by touching the defined channel (see **Figure 6.49**). In order for the user to access the Alarm Set window in the Trend view, the user must log in to the Main Menu as **ADMIN** and be logged in. The user must be logged in with the **Channel Settings** entry authority **ON** and **LOGIN**. Otherwise, the user can not change alarm sets while in Trend view.

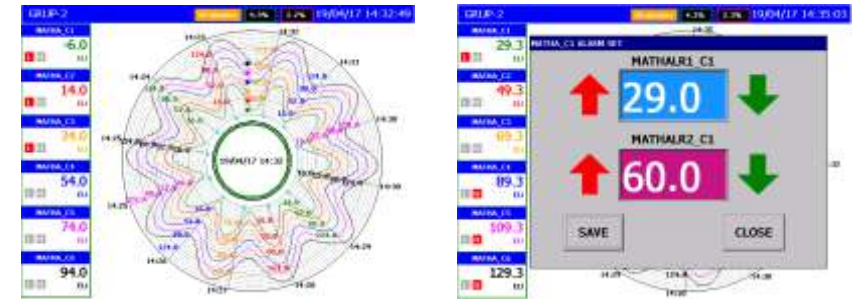

Figure 6.48 Trend Page (Trend Type Circular)

Figure 6.49 Changing alarm set values

To change the graphic drawing direction in the trend view, the GROUPS menu should be selected from the Main Menu. Graphic Type, Horizontal, Vertical or Circular can be selected from the Groups menu (see Figure-6.50). Figure 6.51, Figure 6.52, and Figure 6.53 show the graphical representation of the Graphic Type selection in the Trend view.

### 6.8.1 - Changing Alarm Set Values in Trend View

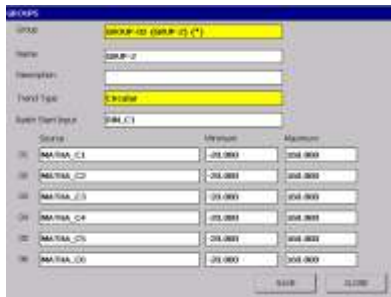

Figure 6.50 Graphical drawing direction selection from Groups menu

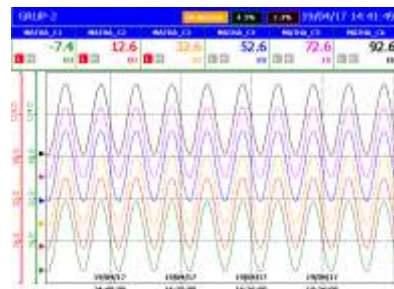

Figure 6.51 If Trend Type HORIZONTAL is selected



Figure 6.52 If Trend Type VERTICAL is selected

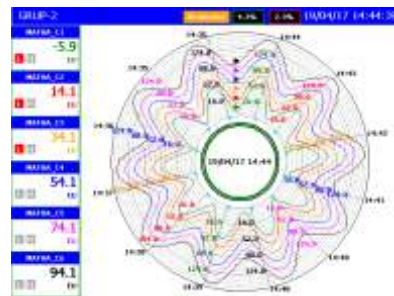

Figure 6.53 If Trend Type CIRCULAR is selected

### 6.8.2 - Batch Start Input

Actions can also be initiated manually via the menus on the screen, and can also be initiated and stopped via digital inputs. This feature is activated in the group configuration by assigning the Start Start Input parameter of the relevant group to one of the 16 digital inputs found in the device. Groups for which the process start function has been defined by the digital input are activated with the assigned digital input, and the last registered operation number is incremented by one to start a new process. This process continues as long as the digital input is active, and the process is stopped by recording the interruption of the digital input.

When entered into the GROUPS menu, the **Batch Start Input** is defined (Figure 6.54). The desired group is selected from 6 groups. The Process **Batch Start Input** for the selected group is defined. For example, in Figure 6.54, group 2/1 digital input / 6 sources are selected.

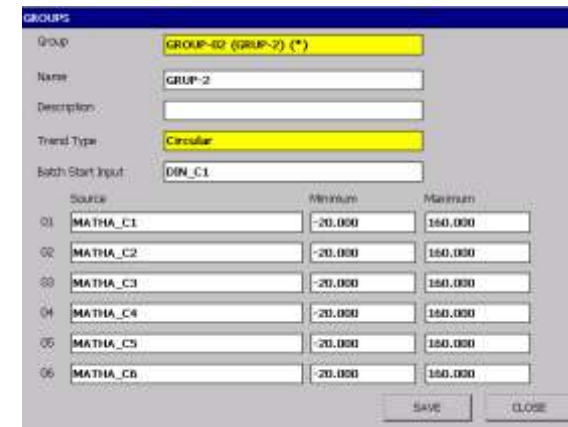

Figure 6.54 Group Configuration Page

### 6.8.2 - Batch Start Input

When the Batch Start Input key is pressed, the window shown in Figure 6.55 appears. Here, Digital Inputs are selected. Channels are given in order from 1 to 16. If the channel is selected, the process is started when that channel is activated and the process is stopped when it is inactive.

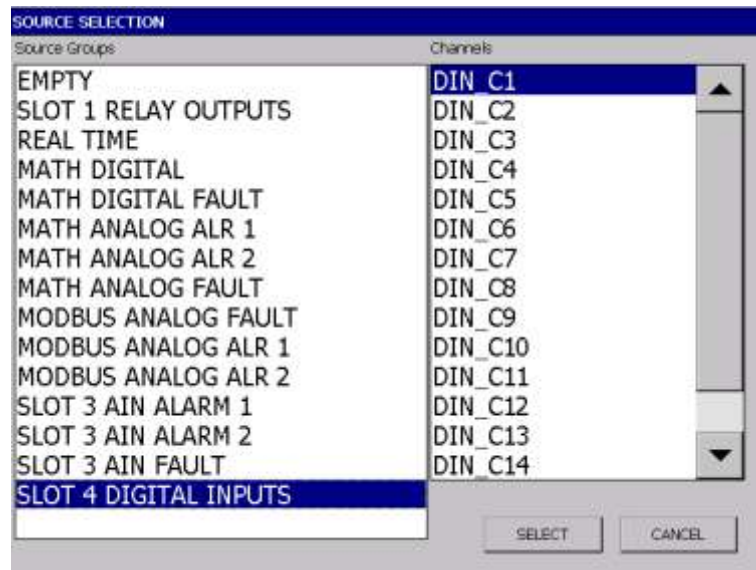

Figure 6.55 Source Selection Page

### 6.8.2 - Batch Start Input

Figure 6.56 shows the process number initiated when the digital input is activated, Figure 6.57 shows the passivation status of the digital input, and Figure 6.58 shows the case where the process number is incremented and the new process is started when the digital input is reactivated.

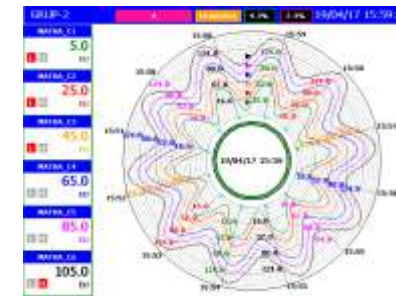

Figure 6.56 Digital input active

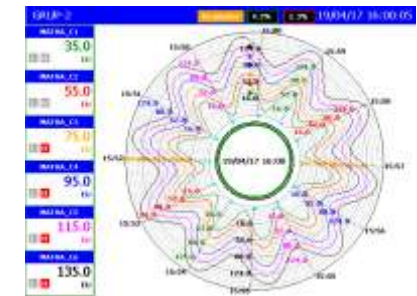

Figure 6.57 Digital input passive

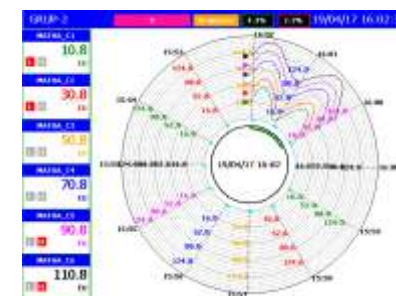

Figure 6.58 Digital input active



### 6.8.2 - Batch Start Input

The transaction table for each group is separated. If the **Trend Page** is displayed in which group, the process table of that group can be displayed. When the **Trend Page** of the relevant group is selected, the running processes and previously completed processes can be displayed by pressing the button (see **Figure 6.59**, **Figure 6.60**, **Figure 6.61** and **Figure 6.62**). Trend can be watched by selecting a previously completed process and pressing **Open**. The Stop key **Stops** the selected operation if it is running. The system automatically restarts with a new transaction number even if the operation that is activated by the digital input is stopped.

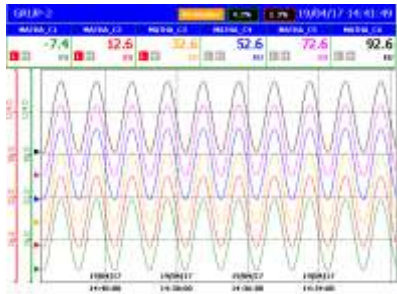

Figure 6.59 For example, GROUP-2 Trend Page



Figure 6.60 Press  to select Open/Stop Batch

### 6.8.2 - Batch Start Input



Figure 6.61 GROUP-1 Page, Open Batch



Figure 6.62 GROUP-1 Page, Stop Batch

## 6.8.2 - Batch Start Input

The data stored in the device can be downloaded to the computer via USB or ETHERNET connection with the E-PR-110 DATA EXPLORER program and the printer output can be retrieved. A sample output is displayed below.

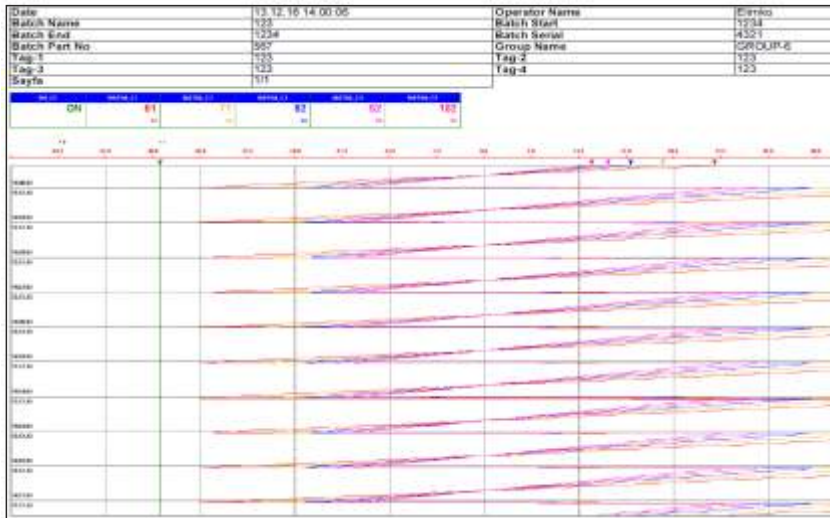

## 6.9 - Custom Tables

Up to 10 custom linearization tables can be defined for linear channels. These tables define input and output relations for non standart sensors.

<b>Table Name:</b>	10 character long table name.
<b>Step Count:</b>	Determines number of linearization steps. It can be maximum 20 steps.
<b>X (%):</b>	Determined percentage of the input values in the respective linearization step.
<b>Y:</b>	X (%) determines the value to be displayed in response.
<b>Up-Down:</b>	Both keys can be used to scroll between steps.

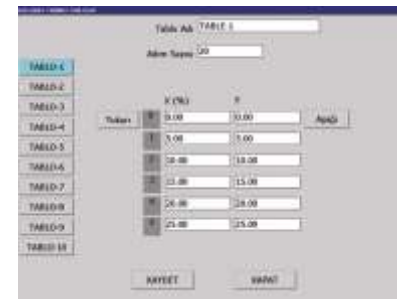

Figure 6.47 Custom Tables Page



Figure 6.48 Analog Input page table selection



## 6.10 - Archive

The configuration and archived data saved in the device's non-volatile memory can be easily synchronized to an external flash memory by connecting a USB Flash Memory to the USB port of the recorder. Prior to the synchronization, user should select the external memory device using **Directory Name** parameter. After selecting the external memory device, synchronization is initiated by pressing **SYNCHRONIZE** button. While synchronizing, user is strongly advised not to perform any operation. Synchronized data can be used for further data analysis in Data Explorer Pro Software. **RESET ARCHIVE** button is used to delete all stored data archives. Resetting archive causes all records to be lost irreversibly.

<b>Sync. Direction:</b>	<b>Sync. Direction</b> determines synchronization direction. <b>DEVICE TO DISC</b> option transfers the data from device to external disc. <b>DISC TO DEVICE</b> does the reverse operation.
<b>Directory Name:</b>	Directory name selected directory located on the external disc. Synchronization reads or writes the data to/from the directory <b>[Selected Directory]\E-PR-110-[Tag]\Archive</b> depending on synchronization direction.
<b>Sync. Type:</b>	Three different data transfer options are available for synchronization. <b>COMPLETE</b> option transfers all data available for synchronization. <b>UP TO DATE</b> option transfer only the new data which is saved after the last synchronization. From the date option transfers data starting from the date which is set in <b>FROM A DATE</b> parameter.

## 6.10 - Archive

<b>Backup:</b>	Backup device is selected by <b>Directory Name</b> parameter.
<b>Backup Type:</b>	Two options with different capabilities and functions are available for Backup Type. User has the chance of either periodic data synchronization or memory extension by selecting <b>COMPLETE BACKUP</b> or <b>MEMORY EXTENSION</b> respectively.
<b>Backup Period:</b>	Determines backup period when Backup Type is set to <b>COMPLETE BACKUP</b> . Selectable periods are <b>every day</b> , <b>every week</b> and <b>every month</b> .

## 6.10 - Archive

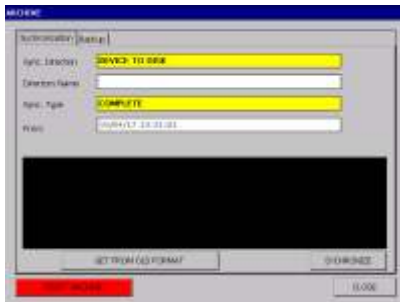

Figure 6.49 Archive Synchronization Page

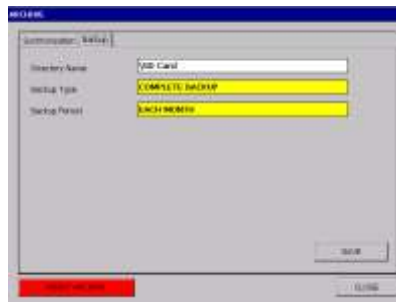

Figure 6.50 Archive Backup Page

## 6.11 - E-mail

Recorder can be configured to send e-mail reports containing instantaneous process values and states up to 4 recipients at adjustable periodic times or by multiple configurable triggers such as sources and general events.

### 6.11.1 - Server Adjustments

<b>Server:</b>	SMTP incoming mail server
<b>Port:</b>	SMTP port number
<b>SSL:</b>	Disable or Enable SSL.
<b>User:</b>	User Account Name
<b>Password:</b>	User Account Password

Example settings for free Google mail service;

**Server:** smtp.google.com

**Port:** 587

**SSL:** ON

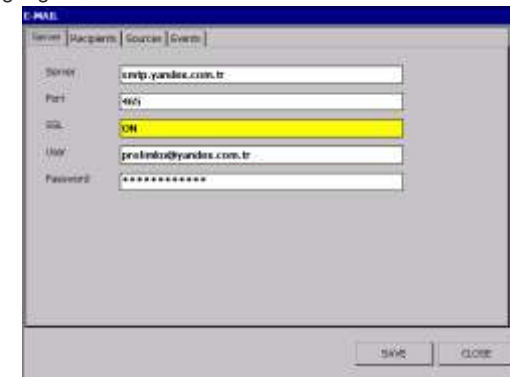
Figure 6.51  
E-MAIL Server  
Page

### 6.11.2 - Recipient Adjustments

**Recipient 1-4:** Up to 4 recipient can be defined for e-mail reports. Unused recipients should be left blank.

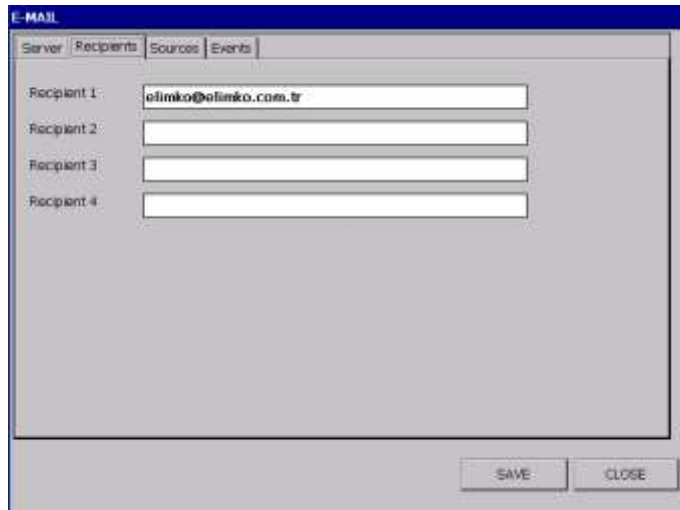

The screenshot shows a web application window titled "E-MAIL" with a tabbed interface. The "Recipients" tab is selected. It contains four input fields labeled "Recipient 1" through "Recipient 4". The first field contains the email address "elimko@elimko.com.tr". The other three fields are empty. At the bottom right, there are "SAVE" and "CLOSE" buttons.

Figure 6.52 E-MAIL Server Page

### 6.11.3 - Source Adjustments

**Source 1-8:** Up to 8 sources which will trigger e-mail notification to the recipients can be defined. For periodic e-mail notification, one of the real time channels with required interval should be assigned to any of the sources.

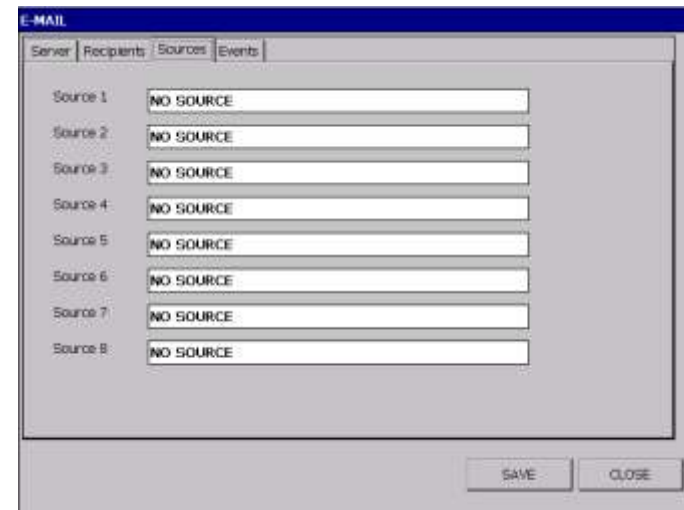

The screenshot shows a web application window titled "E-MAIL" with a tabbed interface. The "Sources" tab is selected. It contains eight input fields labeled "Source 1" through "Source 8". Each field contains the text "NO SOURCE". At the bottom right, there are "SAVE" and "CLOSE" buttons.

Figure 6.53 E-MAIL Sources Page

6.11.4 - Events

<b>On New Alarm:</b>	ON or OFF selectable. If ON is selected, a new e-mail is sent when an alarm occurs.
<b>On New Instrument Log:</b>	ON or OFF selectable. If ON is selected, a new e-mail is sent when a new instrument log is added.
<b>On New Operator Log:</b>	ON or OFF selectable. If ON is selected, a new e-mail is sent when a new operator log is added.
<b>On New Digital Log:</b>	ON or OFF selectable. If ON is selected, a new e-mail is sent when a new digital log is added.

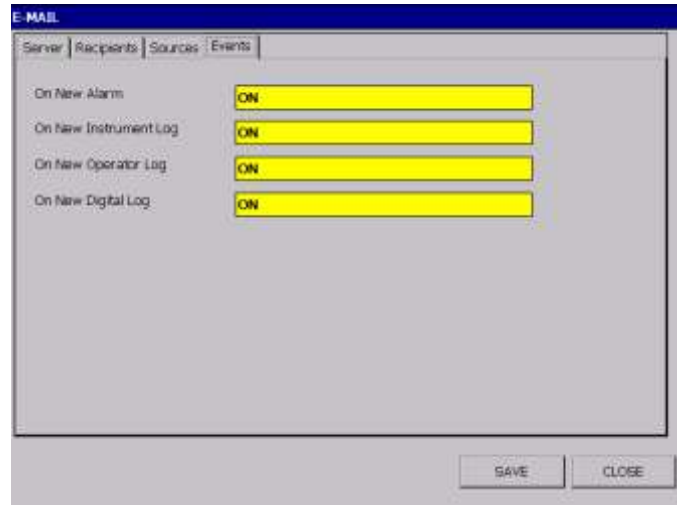

Figure 6.54 E-MAIL Events Page

6.12 - PID

PID configuration window is accessed from MAIN MENU by pressing PID button. 12 PID control loop with different control parameters can be defined for various control applications

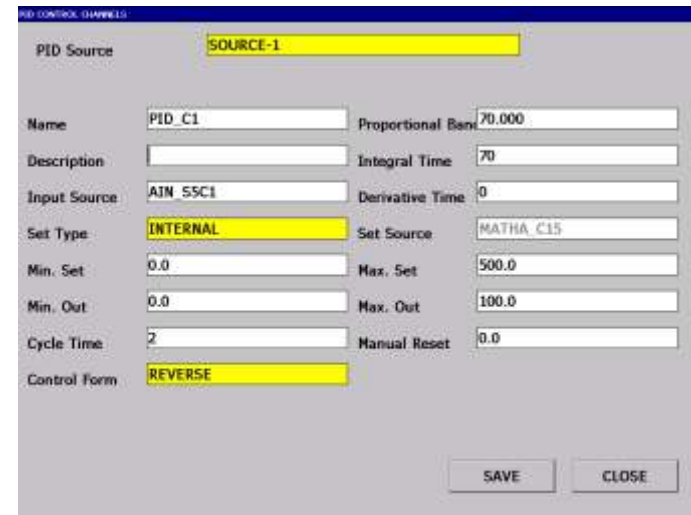

Figure 6.55 PID configuration window

## 6.12 - PID

<b>PID Source:</b>	PID Source to be configured.
<b>Name:</b>	Maximum 12 characters can be entered. Defines the PID Source name.
<b>Description:</b>	Maximum 50 characters can be entered. Additional explanation can be entered.
<b>Input Source:</b>	Determines PID control loop input variable (the process variable to be controlled). The input source can be assigned one of the analog channels defined in the recorder. It can be slot analog inputs, modbus channels or math channels)
<b>Set Type:</b>	Determines set input style of PID control loop. When selected as <b>INTERNAL</b> , set input is entered manually using on screen keyboard (see Figure 6.56). Conversely, when selected as <b>EXTERNAL</b> , set input is applied using an external analog source which is defined by the parameter <b>Set Source</b> .
<b>Min. Set:</b>	Minimum configurable internal set value.
<b>Max. Set:</b>	Maximum configurable internal set value.
<b>Min. Out:</b>	Minimum output value in %percentage. When the calculated output value is less than the minimum output value, the output value is set to minimum output value.
<b>Max. Out:</b>	Maximum output value in %percentage. When the calculated output value is more than the maximum output value, the output value is set to maximum output value.

## 6.12 - PID

<b>Cycle Time:</b>	Cycle time determines the PID PWM output period and is only applied to the digital outputs and is entered in seconds. Short values of cycle times result more precision and accurate control but may cause the control element (actuator) wear faster than would be with long cycle times.
<b>Control Form:</b>	Determines the control form of PID output. <b>REVERSE</b> output form makes the control output increase when the error signal (PV – Set) increases, conversely <b>FORWARD</b> selection makes the control output decreases when the error signal increases. When deciding the control form of PID Loop, how the control output will affect the process variable should be in mind. For instance cooling outputs causes a reverse reaction of temperature output.
<b>Proportional Band:</b>	Proportional band of PID loop in engineering unit.
<b>Integral Time:</b>	PID loop integral time in seconds. 0 value of integral time disables integration.
<b>Derivative Time:</b>	PID loop derivative time in seconds. 0 value of derivative time disables derivation.
<b>Set Source:</b>	Please see <b>Set Type</b> parameter.
<b>Manual Reset:</b>	Output value corresponding to zero error signal(PV-Set). %50 is recommended if there is no priority information.

## 6.12 - PID

PID Sources can be directed to analog output, relay or digital output channels. When the analog outputs are used for control signal, Zero and Span parameter of the analog output should be assigned 0 and 100 respectively. When the digital output sources are used for control signal, PWM sources of the digital sources should be assigned to the PID source to be directed.

The screenshot shows the 'SLOT CHANNELS' configuration window for Slot 2, which is set to '2 ANALOG OUTPUT'. The 'Output' tab is selected. The configuration fields are as follows:

Field	Value
Name	AOUT_C1
Description	
Source	NO SOURCE
Type	mA
Min	4.0
Max	20.0
Zero	0.000
Span	400.000

Buttons for 'SAVE' and 'CLOSE' are visible at the bottom right.

Figure 6.56 Definition of PID Source to Analog Output

## 6.12 - PID

When the first group channel of a group is assigned to a PID source, usual Trend View appears different and turns to PID control page form which provides a clear display of PID process variables and enables user to enter manual set and control output. Please see Figure 6.74 and 6.75.

The screenshot shows the 'SLOT CHANNELS' configuration window for Slot 1, which is set to '1 RELAY OUTPUT'. The 'Output' tab is selected. The configuration fields are as follows:

Field	Value
Name	RELAY_S1C1
Description	
Off Message	OFF
On Message	ON
Source 1	NO SOURCE
Source 2	NO SOURCE
Source 3	NO SOURCE
Source 4	NO SOURCE
Source 5	NO SOURCE
PWM Source	NO SOURCE
PWM Period	1 second(s)

Buttons for 'SAVE' and 'CLOSE' are visible at the bottom right.

Figure 6.57 Definition of PID Source to Relay Output

6.12 - PID

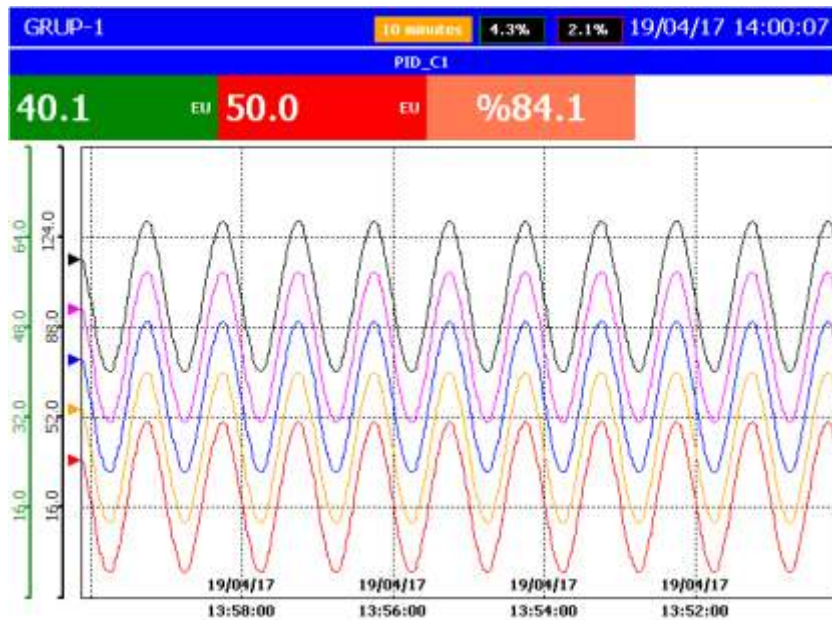

Figure 6.74 PID Trend Page

6.12 - PID

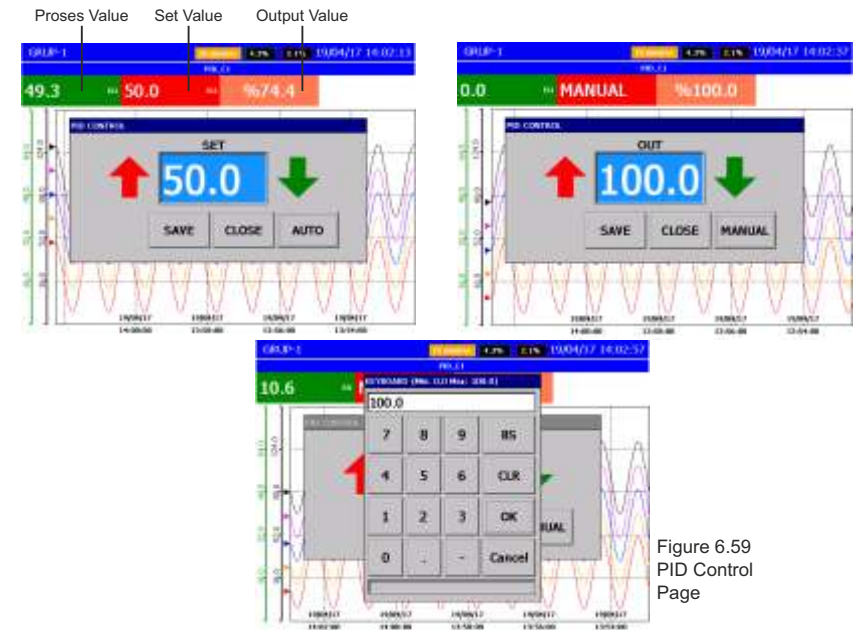

Figure 6.59 PID Control Page

To change the set value, click on Set Value on TREND view screen and click PID Source on the BAR or DIGITAL view screen to open the PID CHECK window.

### 6.12 - PID

By using the set value arrows from the opened window, you can change it by entering set value directly from the keyboard which is opened by touching **SET** on the **PID CONTROL** window can only be opened by users who have the authority to enter the **ADMIN** and Channel Settings menu while in **TREND**, **BAR** and **NUMERIC VIEW**. If the Set Type of the **PID** source is **EXTERNAL** selected, the **PID CONTROL** window will not open.



Figure 6.74 PID Control Page

Figure-6.76 also shows the percentage of the output on the **Overview Page**, rather than the status indication at the relay outputs assigned to the PWM Source.

### 7 - CONNECTION DIAGRAMS

The back panel view of E-PR-110 device is shown at the below figure. There are 4 slots at the back panel.

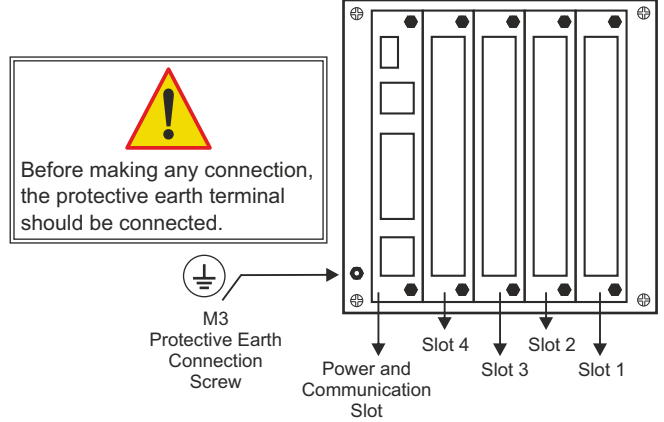

Figure 7.1 E-PR-110 Rear Panel

The **Power and Communication Slot** is fixed for every device and Power Supply, Transmitter Supply, RS-485 and Ethernet connections are made to this slot (see Figure 7.2, Appendix 1). Slots 1-4 can be any of Analog Input, Digital Input, Digital Output, Analog Output or Relay Output depending on configuration.

- Analog Input (3 Channels, AIN)
- Analog Input (6 Channels, AIN)
- Analog Output (4 Channels, AOUT)
- Digital Input (16 Channels, DIN)
- Digital Output (16 Channels, DOUT)
- Relay Output (6 Channels, RELAY)



### 7 - CONNECTION DIAGRAMS

The connection of Analog Input, Digital Input/Output or Relay Output cards are given in **Figure 7.3**, **Figure 7.4**, **Figure 7.5** and **Figure 7.6** respectively. In order to change the cards on 1-4 slots, dismantle top and bottom screws of the related slot and pull out the card. After placing the desired card fix the screws again. During changing or adding card, device should be powered off. After each new card configuration, it must be registered by scanning new configuration. Please see **Section 6.5.HARDWARE**.

- The terminals of the device are electrically live. While the device is powered, never touch to the terminals.
- Before operating the device, ensure that the device is correctly configured. Incorrect configuration could result malfunction.

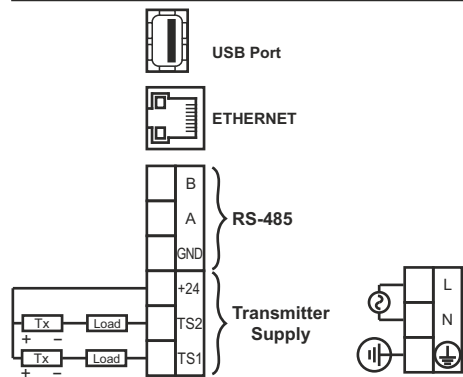
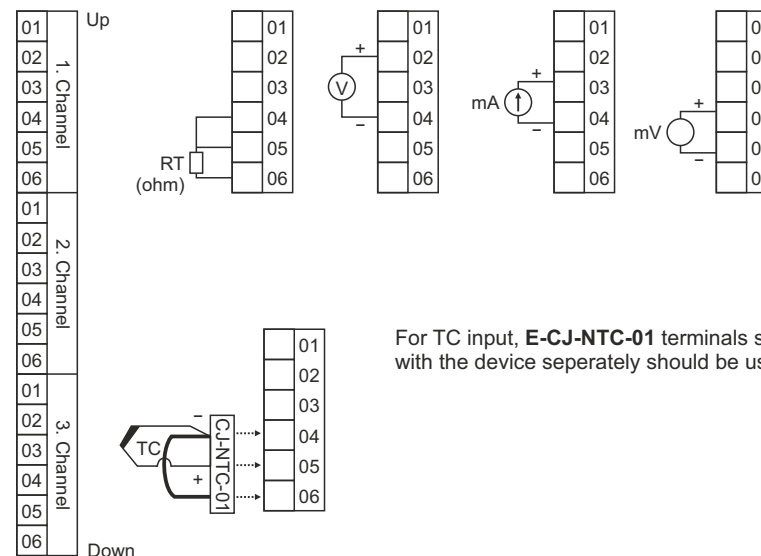

Figure 7.2 Power, Transmitter Supply, RS-485 and Ethernet Connections

Depending on analog output and relay output card configuration, certain number of 2 wire transmitter can be supplied by TS1 and TS2 returns as shown on the **Figure 7.2**. The loads shown on the figure can be the mA inputs of analog input cards. For each lines (TS1 and TS2), maximum number of 2 wire transmitter is limited 6 (Max. 130 mA for each of them). In addition, the total number of transmitters to be supplied is also limited by the total number of relay and analog outputs such that the total number of relay, analog outputs and 2 wire transmitters is limited to 18.

### 7 - CONNECTION DIAGRAMS



For TC input, **E-CJ-NTC-01** terminals supplied with the device separately should be used.

Figure 7.3 Analog Input Card Connection Diagrams (3 Channels)

7 - CONNECTION DIAGRAMS

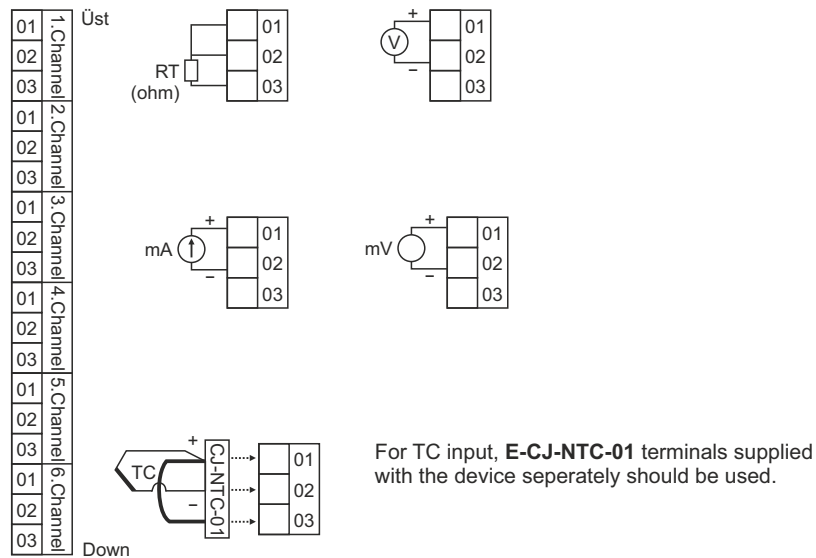

Figure 7.4 Analog Input Card Connection Diagrams (6 Channels)

7 - CONNECTION DIAGRAMS

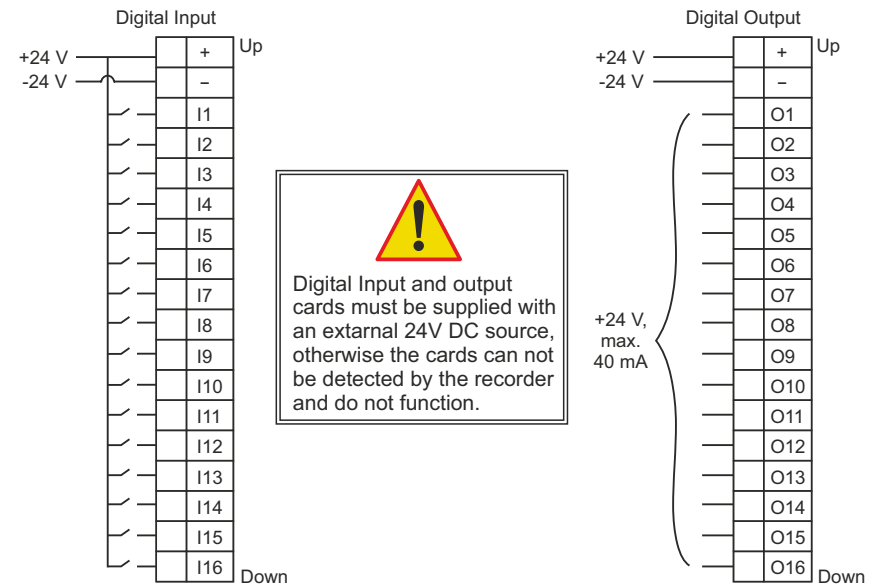
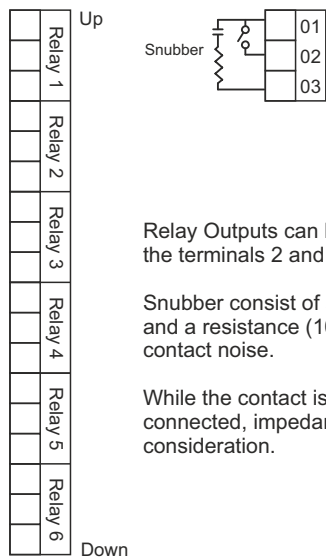

Figure 7.5 Digital Input&Output Cards Connection Diagrams

7 - CONNECTION DIAGRAMS



Relay Outputs can be used with snubbers. To use with snubber, the terminals 2 and 3 should be short circuited with a suitable cable.

Snubber consist of serially connected a capacitor (10nF, 630 V) and a resistance (100 Ω, 1/4 W) and can be used to suppress the contact noise.

While the contact is used for switching AC signals and snubber is connected, impedance of the snubber should be taken into consideration.

Figure 7.6 Relay Output Card Connection Diagrams

7 - CONNECTION DIAGRAMSI

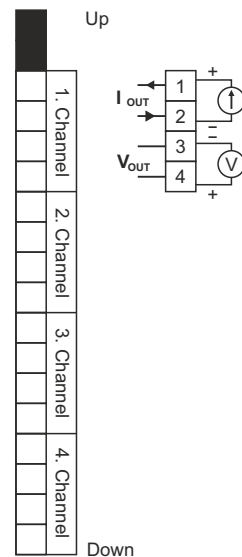

Figure 7.7 Analog Output Card Connection Diagrams

## 8 - DATA TRANSFER COMMUNICATION PROTOCOLS

E-PR-110 series recording devices has several standard connectivity options for easy transfer of recorded data. Standard of the shelf USB Mass storage disks up to 4 GB can be plugged from front panel USB ports and all data can be synchronized with a couple of click on the screen. Highly prevalent and known TCP/IP standards such as FTP, HTTP, Modbus TCP/IP are all available at no cost.

### 1) USB Mass Storage Device

Rear panel USB port provides easy connection of USB mass storage devices. Only FAT16 and FAT32 formatted disks up to 4 GB supported. For data transfer, please check **Section 6.10 ARCHIVE**.

### 2) HTTP and FTP Server Connection

Only just entering the IP address of the recorder to web browser enables user to connect Web server to monitor instantaneous values all in one place (http:// IP Address). In the same way accessing Web Server, FTP server can be utilized by entering FTP address of the recorder which is in the form of ftp://IP address, to the FTP supported web browsers or FTP clients. FTP and HTTP accessed are write protected (read only).

### 3) TCP/IP Modbus Master and Slave Connection

In addition to HTTP and FTP protocol support, the recorder serves as a Modbus Slave or Master unit over TCP/IP network. All registers given in **Appendix 3** can be read or write depending on access rights.

### 4) RS-485 Modbus Master and Slave Connection

The recorder can also be configured run as a Modbus Master or Slave over RS-485 communication network. All registers given in **Appendix 3** can be read or write depending on access rights.

## 8 - DATA TRANSFER COMMUNICATION PROTOCOLS

### 5) Barcode Scanner Connection

Please check Appendix 4 for detailed explanation.

### 6) Wi-Fi®



Indicates that the Wi-Fi connection is not installed. The icon is pressed to establish a Wi-Fi connection. In the window that opens, enter the network SSID and Password. The network connection is established by pressing the Connect button.



Indicates that the network connection is installed. Under the Wi-Fi icon, the SSID of the network to which the connection is made is named.

## 9 - APPENDIXES

### Appendix 1 - Ethernet Connection

E-PR-110 recorder can connect to the Ethernet networks with its standard 10/100 M Bit Ethernet port (see Section 7. CONNECTION DIAGRAMS). Communication is performed using standard TC/IP. Please see Section 6.5 HARDWARE menu for TCP/IP settings. Only FTP application is available in standard software. FTP address of the recorder is always in the form of ftp://ipadress and there is no password protection. Recorded data and configuration can be reached using FTP Clients. In addition to that, recorded data can be analyzed offline with E-PR-1100 Data Explorer Software by instant one-click FTP synchronization.

#### Ethernet Network Connections

Ethernet connection is done through the RJ 45 connector located at the bottom of E-PR-110 (see Section 7. CONNECTION DIAGRAMS). The device can be connected to a PC directly (Figure 9.1) or a network hub. While the device connected to a PC crossover cable must be used. Normal cable should be used for hub connection. The pin numbers and signals for RJ 45 connector are given below (Figure 9.2).

**NOTE:** Maximum cable length is limited to 100m. If longer cable required, repeaters and gateways must be used to boost signal strengths.

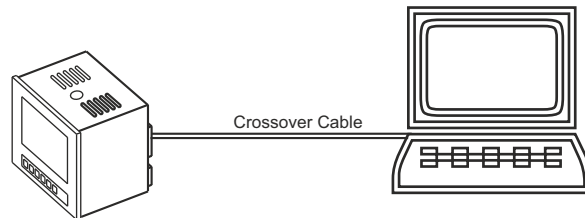

Figure 9.1 Computer Connection

### Appendix 1 - Ethernet Connection

#### RJ45 Pins

PIN NUMBER	SIGNAL
1	TD + (Transmit +)
2	TD - (Transmit -)
3	RD + (Receive +)
4	Unused
5	Unused
6	RD - (Receive -)
7	Unused
8	Unused

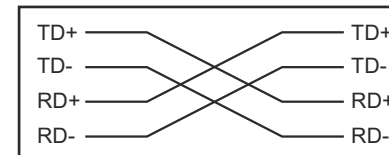

Figure 9.2 Crossover Cable Connection

## Appendix 2 - Equation Creation Using Math Editor

Equation for Math Analog and Math Digital can be easily created using Math Editor. User can apply arithmetic operators (+, -, \*, /), comparison operators (>, <, >=, <=, ==), constants, channel process values and miscellaneous functions into equations. Parenthesis can be added to equations for grouping the operations, if necessary. The most left operator in the same parenthesis has the highest precedence. Operator precedence can be changed using parenthesis. Home key sets the cursor to the left most position, End key sets the cursor to the right most position, <--- key shifts the cursor one character left and ---> key shifts the cursor one character right. Delete and Backspace keys delete one character towards the left or right respectively. Clear key clears the existing equation. Channel process values can be included in to the equations by pressing SOURCE key. RUN key runs the equation for testing. Pressing OK key saves the equation, CANCEL key cancels all operations.

**Script** is defined in the key device used for the incorporation of equality of a team ready to function. When pressed **Script** out the following options.

**\$(second)**: Count of seconds indicates that the system time.

**\$(minute)**: The system indicates that the clock match minute.

**\$(hour)**: It displays the system time.

**\$(year)**: Which it indicates that year on the system.

**\$(month)**: Indicates that the system on which month.

**\$(day)**: Indicates that the day on which the System.

**\$(coretemp)**: The device shows the core temperature of the processor.

**\$(moduletemp)**: The device displays the temperature of the processor module.

**cj()**: CJ (SlotNo, ChannelNo) is used with parameters. The channel parameters gives the cold spot temperature of the specified slot. Slot and Channel Number should be a zero index (cj (0,0): 1.Slot channel 1 's cold spot temperature data.).

## Appendix 2 - Equation Creation Using Math Editor

**microvolt()**: Microvolts (Slotno, ChannelNo) is used with parameters. Parameters of the analog input channels of the slot referred to as raw data the value of reading microvolts. Slot and Channel Number should be a zero index (microvolts (0.0): 1.Slot ' channel 1 ' s value in microvolts is reading.).



Figure 9.3 MATH EDITOR Page



Figure 9.4 Script selection button

Appendix 2 - Equation Creation Using Math Editor

FUNCTION	USAGE	DESCRIPTION
<	Op1 < Op2	If Op1 is smaller than Op2 "1", other states "0"
>	Op1 > Op2	If Op1 is bigger than Op2 "1", other states "0"
<=	Op1 <= Op2	If Op1 is smaller and equal than Op2 "1", other states "0"
>=	Op1 >= Op2	If Op1 is bigger and equal than Op2 "1", other states "0"
==	Op1 == Op2	If Op1 is equal Op2 "1", other states "0"
sin()	sin(Op)	Op is radian.
cos()	cos(Op)	Op is radian.
tan()	tan(Op)	Op is radian.
abs()	abs(Op)	Op is absolute value.
sroot()	sroot(Op)	Square root
log()	log(Op)	The base-10 logarithm
ln()	ln(Op)	The natural logarithm
pow()	Pow(Op1,Op2)	Op1 <sup>Op2</sup>
sqr()	sqr(Op)	Op <sup>2</sup>
pow10()	pow10(Op)	10 <sup>Op</sup>
exp()	exp(Op)	e <sup>Op</sup>
and()	and(Op1,Op2,...,Opn)	Digital AND operator
or()	or(Op1,Op2,...,Opn)	Digital OR operator
not()	not(Op1,Op2,...,Opn)	Digital NOT operator
xor()	xor(Op1,Op2,...,Opn)	Digital XOR operator
hs()	hs(Op1,Op2,...,Opn)	Select the biggest
ls()	ls(Op1,Op2,...,Opn)	Select the smallest
mux()	mux(i,Op1,Op2,...,Opn)	Selects parameter Op(i+1). Zero index selects Op1.

Figure 9.5 Operator and Function description

Appendix 3 - Modbus RTU Communication Addresses

Modbus RTU Register addresses can be reached from **MODBUS TABLE** window by pressing the MODBUS TABLE button in the **Main Menu**. Digital channel grouped by slots are represented with a single address. Data format of this representation is given in **Figure 9.7**.

Address	Group	Name	Size	Type
0500	SLOT 1 ANALOG INPUTS	AIN_S1C1	4 Byte (Float)	ANALOG
0502	SLOT 1 ANALOG INPUTS	AIN_S1C2	4 Byte (Float)	ANALOG
0504	SLOT 1 ANALOG INPUTS	AIN_S1C3	4 Byte (Float)	ANALOG
0506	SLOT 1 AIN ALARM 1	----	4 Byte (Integer)	DIGITAL
0508	SLOT 1 AIN ALARM 2	----	4 Byte (Integer)	DIGITAL
0510	SLOT 1 AIN FAULT	----	4 Byte (Integer)	DIGITAL
0512	SLOT 1 RELAY OUTPUTS	----	4 Byte (Integer)	DIGITAL
0514	REAL TIME	----	4 Byte (Integer)	DIGITAL
0516	MATH DIGITAL	----	4 Byte (Integer)	DIGITAL
0518	MATH DIGITAL FAULT	----	4 Byte (Integer)	DIGITAL
0520	MATH ANALOG	MATHA_C1	4 Byte (Float)	ANALOG
0522	MATH ANALOG	MATHA_C2	4 Byte (Float)	ANALOG
0524	MATH ANALOG	MATHA_C3	4 Byte (Float)	ANALOG
0526	MATH ANALOG	MATHA_C4	4 Byte (Float)	ANALOG
0528	MATH ANALOG	MATHA_C5	4 Byte (Float)	ANALOG
0530	MATH ANALOG	MATHA_C6	4 Byte (Float)	ANALOG
0532	MATH ANALOG	MATHA_C7	4 Byte (Float)	ANALOG
0534	MATH ANALOG	MATHA_C8	4 Byte (Float)	ANALOG

Figure 9.6 MODBUS Table

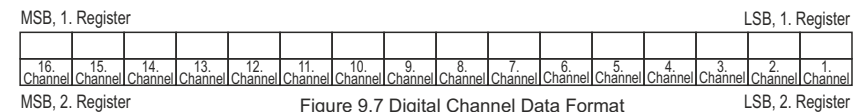

Figure 9.7 Digital Channel Data Format

#### Appendix 4 - Barcode Reader

Rear panel USB port serve as a hub to 2D Barcode scanners which are prevalently adapted in certain industrial application for easy and secure data input devices. All standard input windows in the device such as numeric and text boxes support barcode scanner input. In addition, barcode scanners provide several advantages in batch recording operations. These operations are Start Batch, Stop Batch and Batch Name Input. Barcode scanner should be configured as an USB keyboard emulator and barcode termination character should be set to horizontal tab (ASCII 9). In order to start a batch, "START" barcode is scanned first and than Batch Name barcode is scanned just afterward in 15 seconds. Any scan after that time period will be discarded. Batches can be run concurrently thus user can start additional batches in the same way described earlier. Scanning STOP barcode first and scanning the Batch Name barcode afterward stops the respective batch.

START and STOP barcodes are given below.



START



STOP



TS EN ISO 9001

Quality Management System Certificate

**KY-PR110-0417-1**